



The original electronic force measurement device with integral display.

In production since 1979, this is the latest version of this world renowned product.

All LLP's have push button control for: tare, units (kg, lbs, kN & tonnes), peak hold, pre set tare, audible setpoint alarm and overload counter.

Remote output is fitted as standard allowing connection to our range of accessories.

All models are supplied with carry/storage case. All models are supplied with carry/storage case.

DIMENSIONS (SEE TABLE BELOW)

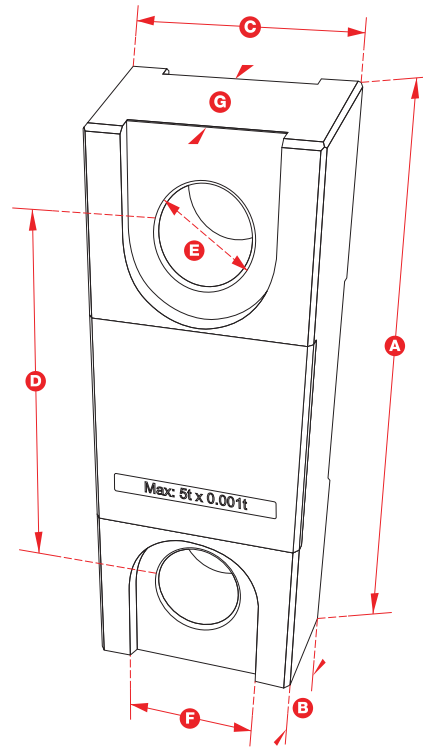

Part Number	LLP250KG	LLP500KG	LLP1T	LLP2T5	LLP5T	LLP12T	LLP25T	LLP50T	LLP100T	LLP200T	LLP250T	LLP500T*	
Capacity	250kg	500kg	1000kg	2.5t	5t	12t	25t	50t	100t	200t	250t	500t	
Resolution	0.05kg	0.2kg	0.5kg	0.001t	0.001t	0.002t	0.005t	0.01t	0.05t	0.1t	0.1t	0.2t	
Units	kg, kN, lbs		t, kg, kN, lbs					t, kg, kN		t, kN	t, kN	t, kN	t, kN
Weight	1.5kg	1.5kg	1.5kg	1.5kg	2.2kg	3.5kg	5.2kg	10.9kg	37kg	80kg	80kg	260kg	
Safety Factor	50:1	25:1	12:1	5:1	5:1	5:1	5:1	5:1	4:1	5:1	4:1	1.5 : 1	
Battery Type	9v PP3												
Battery Life	80 hours continuous												
Display Type	25mm LCD												
Op Temp	-10 to 50c												
Accuracy	± 0.3% of applied load												
Protection	IP65												
Dimension A	204	204	204	204	249	305	340	424	608	690	690	900	
Dimension B	43	43	43	43	43	47	60	75	99	150	150	120	
Dimension C	101	101	101	101	101	101	110	163	255	305	305	380	
Dimension D	146	146	146	146	165	193	215	230	320	350	350	468	
Dimension E	24.5	24.5	24.5	24.5	38	47.5	55	76	108	125	125	183	
Dimension F	47.5	47.5	47.5	47.5	66								
Dimension G	19	19	19	19	32								
Crosby Shackle	G210	G210	G210	G210	G210	G210	G210	G2140	G2140	G2140	G2140	G2160	

* Manufactured from steel.

LOADLINK PLUS

