

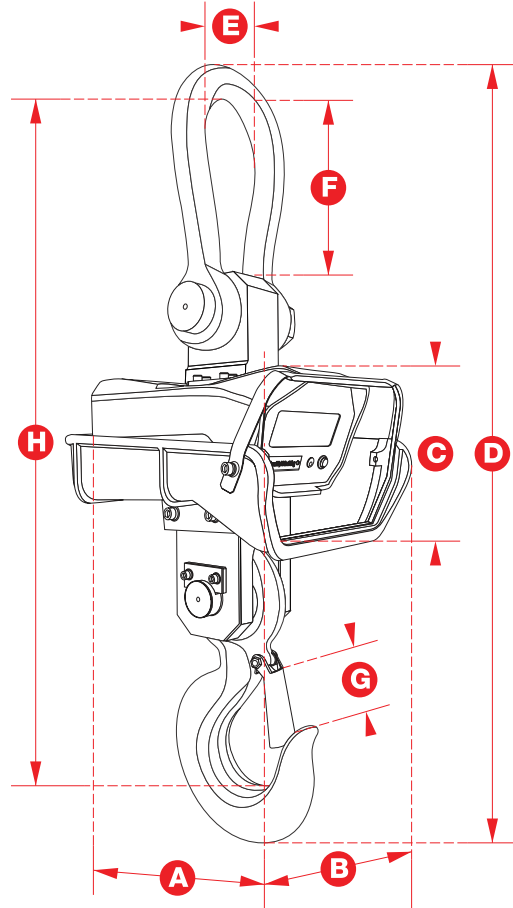

Heavy duty crane scale designed to be used in high temperature environments.
 Available in capacities 5 and 10 tonne.
 Bright LED display makes it easy to read in the lowest light applications.
 Fitted with heat shield and specially filmed high temperature glass front.
 Supplied with remote control with tare and hold facility.

DIMENSIONS (SEE TABLE BELOW)



Part Number	JWF5T	JWF10T
Capacity	5000kg	10,000kg
Resolution	2kg	5kg
Units	kg	kg
Weight	42kg	77kg
Battery Type	Internal rechargeable	
Battery Life	20hrs	
Display Type	30mm LED	
Operating Temp	1600c at 2 metres	
Accuracy	±0.3% of applied load	
Dimension A	420	420
Dimension B	300	300
Dimension C	200	200
Dimension D	750	1040
Dimension E	90	140
Dimension F	110	230
Dimension G	50	60
Dimension H	640	920

PRICES AND SPECS [mm]

JUMBOWEIGHER FOUNDRY

