

Rigging Accessories



Rigging
Accessories



HG-223

Turnbuckles

What It Takes To Be

“Crosby Or Equal”



HG-228

DESIGN	COMPETITION	CROSBY
<p>The theoretical reserve capability of turnbuckles should be five times the Working Load Limit (FF-T-791). Known as the DESIGN FACTOR, it is usually computed by dividing the catalog ultimate load by the Working Load Limit. The ultimate load is the average load or force at which the product fails or no longer supports the load. The Working Load Limit is the maximum mass or force which the product is authorized to support in general service. The design factor is generally expressed as a ratio, such as 5 to 1.</p>	<p><i>Ask: What is the design factor?</i></p> <p>Most competitors do not provide turnbuckle assemblies that exceed Crosby's Working Load Limits with a design factor of 5 to 1.</p>	<p>All turnbuckles are designed with a design factor of at least 5 to 1. Crosby turnbuckles have the highest Working Load Limits in the industry. Crosby working load limits and design factors are based on extensive testing.</p>
<p>HEAT TREATMENT Heat treatment assures the uniformity of performance and maximizes the properties of the steel. This assures that each turnbuckle will meet its rated strength. The requirements of your job demand this reliability and consistency. All turnbuckle bodies should be normalized to assure uniformity. Turnbuckle end fittings are the components exposed to the highest stress, and should be quenched and tempered. This hardening and tempering process develops a tough material that reduces the risk of a brittle, catastrophic failure. This combination of heat treatment assures the performance of the turnbuckle assembly.</p>	<p><i>Ask: Do they utilize the combination of heat treatment that assures the performance of the turnbuckle assembly?</i></p> <p>Most normalize both the turnbuckle body and end fittings. Some provide turnbuckles in an “as forged” condition.</p>	<p>All turnbuckles are heat treated. Bodies are normalized, and end fittings are quenched and tempered. This combination of heat treatment provides a turnbuckle assembly that has superior impact and fatigue qualities and assures performance.</p> <div style="text-align: right;">  </div>
<p>GALVANIZE AND THREAD FORM Galvanizing provides the best resistance to corrosion. Turnbuckle ends are the most highly stressed part of the assembly. This stress is at its peak at the root of the threaded shank. The turnbuckle ends should be threaded with a modified thread that minimizes the stress at the root of the thread.</p>	<p><i>Ask: Do they use the modified UNJ Thread?</i></p> <p>Most galvanize their turnbuckles but do not utilize the modified thread.</p>	<p>All turnbuckles are available galvanized. Turnbuckle ends are threaded with a modified UNJ thread. This thread form, in conjunction with quench and tempering gives Crosby turnbuckles their superior impact and fatigue performance.</p>
<p>FULL LINE AND IDENTIFICATION The proper application of turnbuckles requires that the correct type and size of turnbuckle be used. The turnbuckle size, the manufacturer's LOGO, and a product identification code should be clearly and boldly marked in the end fittings as well as in the turnbuckle body. Traceability of the material chemistry is essential for total confidence in the manufacturer of the product. Availability over the full range of sizes of hook, eye, and jaw type turnbuckle assemblies are essential for flexibility in the design of a total system.</p>	<p><i>Ask: Do they have a traceability system?</i></p> <p><i>Ask: Is the full range of type and size turnbuckles offered?</i></p> <p>Most competitors do not have the full line that Crosby produces, or a traceability system.</p>	<p>Crosby forges its logo, sizes, and the Product Identification Code (PIC) into each component of its full line of hook, jaw, and eye type turnbuckles.</p>



Remember, “When buying Crosby, you’re buying more than product, you’re buying Quality.”

Crosby Value Added

- **Charpy Impact Properties:** Crosby's quenched and tempered end fittings and normalized bodies have enhanced impact properties for greater toughness at all temperatures. If requested at the time of order, Crosby can provide Charpy impact properties.
- **Fatigue Properties:** Typical fatigue properties are available for selected sizes. Crosby turnbuckles are designed with quenched and tempered end fittings and modified UNJ threads for improved fatigue properties.
- **Typical Hardness Levels, Tensile Strengths and Ductility Properties:** These properties are available for all sizes.
- **Inspection:** If requested at the time of order, turnbuckles can be furnished proof tested or magnaflux inspected with certificates.
- **Full Line:** Turnbuckle assembly combinations include: Eye and Eye, Hook and Hook, Hook and Eye, Jaw and Jaw, Jaw and Eye.
- **Hot Dip Galvanize:** Turnbuckle components have a high quality "hot dip" galvanize finish. Self colored turnbuckle bodies are available upon request.
- **Jaw Ends:** Jaw ends are fitted with bolts and nuts (1/4" through 5/8"), or pins and cotters (3/4" through 2-3/4").
- **Turnbuckle Eyes:** Eyes are elongated by design, maximizing easy attachment in system and minimizing stress in the eye. For turnbuckle sizes 1/4" through 2-1/2", shackles one size smaller can be reeved through the eye.
- **Turnbuckle Hooks:** Crosby Forges its turnbuckle hooks with a greater cross sectional area that results in a stronger hook with better fatigue properties.
- **Material Analysis:** Crosby can provide certified material (mill) analysis for each production lot, traceable by the Product Identification Code (PIC). Crosby, through its own laboratory, verifies the analysis of each heat of steel. Crosby purchased only *special bar* forging quality steel with specific cleanliness requirements and guaranteed hardenability.



HG-223

Hook & Hook

Meets the performance requirements of Federal Specifications FF-T-791b, Type 1, Form 1, Class 5, and ASTM F-1145, except for those provisions required of the contractor.



HG-225

Hook & Eye

Meets the performance requirements of Federal Specifications FF-T-791b, Type 1, Form 1, Class 6, and ASTM F-1145, except for those provisions required of the contractor.



HG-226

Eye & Eye

Meets the performance requirements of Federal Specifications FF-T-791b, Type 1, Form 1, Class 4, and ASTM F-1145, except for those provisions required of the contractor.



HG-227

Jaw & Eyes

Meets the performance requirements of Federal Specifications FF-T-791b, Type 1, Form 1, Class 8, and ASTM F-1145, except for those provisions required of the contractor.



HG-228

Jaw & Jaw

Meets the performance requirements of Federal Specifications FF-T-791b, Type 1, Form 1, Class 7, and ASTM F-1145, except for those provisions required of the contractor.



HS-251

Stub End

Meets the performance requirements of Federal Specifications FF-T-791b, Type 1, Form 1, Class 3, and ASTM F-1145, except for those provisions required of the contractor.

Remember, "When buying Crosby, you're buying more than product, you're buying Quality."

Wire Rope Thimbles

G-411



- The standard choice for light duty applications and loading conditions.
- Hot Dip galvanized steel.

G-411 meets the performance requirements of Federal Specification FF-T-276b Type II, except for those provisions required of the contractor.

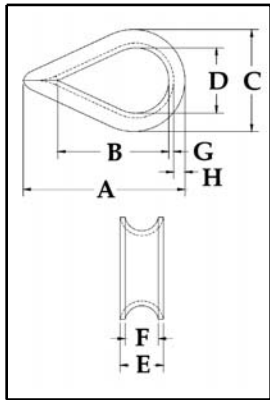

Standard Wire Rope Thimbles

Rope Dia. (mm)	G-411 Stock No.	Weight Per 100 (kg)	Dimensions (mm)							
			A	B	C	D	E	F	G	H
3-4	1037256	1.59	49.3	33.3	26.9	17.5	6.35	4.05	1.25	3.30
5	1037274	1.59	49.3	33.3	26.9	17.5	7.85	5.60	1.25	3.30
6-7	1037292	1.59	49.3	33.3	26.9	17.5	9.65	7.10	1.25	3.30
8	1037318	1.81	54.0	38.1	31.8	20.6	11.2	8.65	1.25	3.30
9-10	1037336	3.04	60.5	41.4	37.3	23.9	13.5	10.4	1.50	4.06
11-13	1037354	5.67	70.0	47.8	44.5	28.7	17.5	13.5	2.05	4.83
16	1037372	15.7	89.0	57.0	60.5	35.1	23.1	16.8	3.30	8.64
18-20	1037390	21.4	95.5	63.5	68.5	41.4	27.4	19.8	3.55	8.64
22	1037416	38.4	127	89.0	81.0	47.8	32.3	23.9	4.05	11.2
24-26	1037434	44.2	145	108	95.5	63.5	35.3	26.9	4.05	10.4
28-32	1037452	79	159	114	109	70.0	44.5	33.3	5.60	12.7

G-414



- Greater protection against wear and deformation of the wire rope eye.
- Longer service life.
- Available in Hot Dip galvanized or Stainless Steel (Type 304).
- Stainless steel recommended for more corrosive environments where greater protection is required.

G-414 meets the performance requirements of Federal Specification FF-T-276b Type III, except for those provisions required of the contractor.

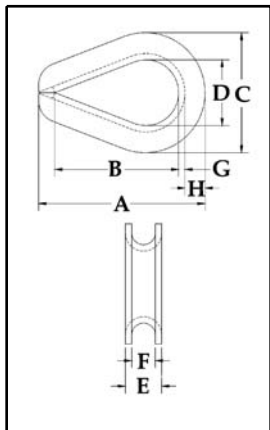

Extra Heavy Wire Rope Thimbles

Rope Dia. (mm.)	Stock No.		Weight Per 100 (kg)	Dimensions (mm)							
	G-414 Galv.	SS-414 Stainless		A	B	C	D	E	F	G	H
* 6-7	1037639	1037960	2.95	55.5	41.4	38.1	22.4	10.4	7.10	1.50	5.85
* 8	1037657	1037988	5.35	63.5	47.8	46.0	26.9	12.7	8.65	2.05	7.10
* 9-10	1037675	1038004	9.80	73.0	54.0	54.0	28.7	16.0	10.4	2.80	8.65
* 11-12	1037693	-	15.7	82.5	60.5	60.5	31.8	18.3	11.9	3.30	9.65
* 13-15	1037719	1038022	23.1	92.0	70.0	70.0	38.1	20.6	13.5	3.55	10.4
* 16	1037755	1038040	34.3	108	82.5	79.5	44.5	24.6	16.8	4.05	12.7
* 18-20	1037773	1038068	72	127	95.5	96.5	51.0	31.0	19.8	5.60	16.8
22	1037791	-	81	140	108	108	57.0	35.1	23.9	5.60	19.1
24-26	1037817	-	142	156	114	125	63.5	39.6	26.9	6.35	22.4
28-32	1037835	-	181	178	130	149	73.0	46.0	33.3	6.35	28.7
32-35	1037853	-	368	230	165	173	89.0	55.5	36.6	9.65	28.7
35-38	1037871	-	587	229	159	181	89.0	65.0	39.6	12.7	28.7
40	1037899	-	771	286	203	207	102	69.0	43.7	12.7	35.1
44	1037915	-	805	310	229	216	114	72.0	46.7	12.7	33.3
48-52	1037933	-	1259	384	305	264	152	78.5	53.0	12.7	38.1
56	1037951	-	1792	435	356	302	178	92.0	60.5	16.0	41.4

* SS-414 sizes available in stainless steel type 304.

Wire Rope Thimbles

G-408 (OPEN PATTERN)

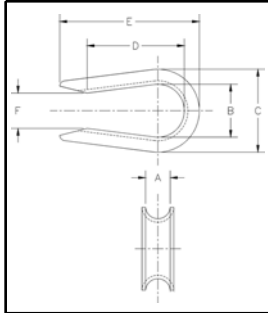

Open Pattern Thimbles

- Recommended for light duty applications in which it is being assembled into another fitting (i.e., shackle or master link).
- Hot Dip galvanized Steel.

Rope Dia. (mm)	G-408 Stock No.	Weight Per 100 (kg)	Dimensions (mm)					
			A	B	C	D	E	F
6-7	1037531	1.36	7.10	17.5	26.9	35.8	51.5	9.65
8	1037559	1.72	8.65	20.6	31.8	38.9	55.0	12.7
9-10	1037577	3.18	11.2	23.9	37.3	43.7	62.5	15.7
11-13	1037595	5.67	13.5	28.4	44.5	37.3	72.0	19.1
16	1037611	11.3	16.8	35.1	60.5	59.5	91.0	25.4

S-412

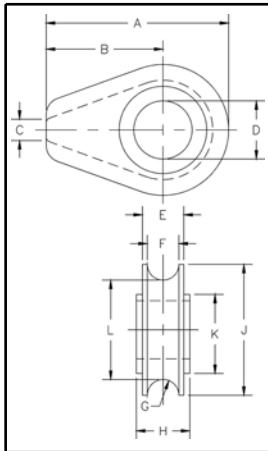

Solid Wire Rope Thimbles

- Fits pin for open wire rope socket, boom pendant clevis and wedge socket.
- Cast Ductile Iron.

Rope Dia. (mm)	S-412 Stock No.	Weight Each (kg)	Dimensions (mm)										
			A	B	C	D	E	F	G	H	J	K	L
13	1037121	.28	71.5	44.5	6.35	26.9	19.1	14.2	7.10	22.4	54.0	41.4	39.6
16	1037149	1.00	119	76.0	9.65	33.3	26.9	20.6	10.4	28.7	86.0	57.0	65.0
18-20	1037167	1.05	119	76.0	9.65	38.1	26.9	20.6	10.4	35.1	86.0	57.0	65.0
22	1037185	2.47	154	97.0	12.7	44.5	35.1	26.9	13.5	41.4	114	82.5	87.5
24-26	1037201	2.38	154	97.0	12.7	54.0	35.1	26.9	13.5	46.0	114	82.5	87.5
28-30	1037229	4.21	184	116	16.0	60.5	44.5	33.3	16.8	52.5	137	98.5	103
32-35	1037247	4.45	184	116	16.0	67.0	49.3	38.9	19.8	58.5	137	98.5	105

Alloy Master Links



A-342



- Alloy Steel — Quenched and Tempered.
- Individually proof tested to values shown.
- For use with chain (S.F.= 4/1), proof tested to 2.5 times the working load limit.
- For use with rope (S.F.= 5/1), proof tested to 2 times the working load limit.
- Sizes from 13 mm to 51 mm are drop forged.

A-342 and A-345 Master Links incorporate markings forged into the product which address two (2) QUIC-CHECK® features: Deformation Indicators — Two strategically placed marks, one on each side of the link, which allows for a QUIC-CHECK® measurement to determine if the link dimensions have changed, thus indicating abuse or overload.

To check, use a measuring device (i.e., tape measure) to measure the distance between the marks. The marks should meet the dimensions as shown in the table. If the measurement does not meet this criteria, the Master Link should be inspected further for possible damage.

Angle Indicators: Forged at 45° angles at each end of the link, they are utilized to quickly check the approximate included angles between two sling legs.

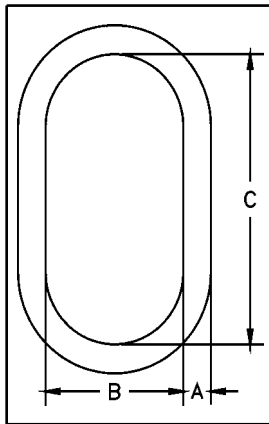

A-342 Alloy Master Links

Size "A" (mm)	A-342 Stock No.	Working Load Limit S.F.= 5:1 For Rope (t) [†]	Working Load Limit S.F.= 4:1 For Chain (t) [*]	Proofload in kN ^{**}	Weight Each (kg)	Dimensions (mm)		
						B	C	Deformation Indicator
** 13	1014262	3.17	2.54	63	.37	63.5	127	76
** 16	1014280	4.08	3.26	81	.69	76.0	152	89
** 19	1014306	5.58	4.46	110	.94	70.0	140	89
** 22	1014315	6.44	5.15	127	1.59	95.5	162	114
** 25	1014324	11.06	8.83	217	2.20	89.0	178	114
** 32	1014342	16.42	13.13	323	4.34	111	222	140
** 38	1014360	25.67	20.54	504	7.36	133	267	165
** 44	1014388	38.51	30.81	756	11.4	152	305	191
** 51	1014404	46.54	37.23	913	16.8	178	356	229
†† 57	1014422	65.6	52.47	1287	24.5	203	406	-
**†† 63	1014468	66.8	58.00	1311	30.7	203	406	-
†† 70	1014440	98.4	78.71	1930	39.8	241	406	-
†† 76	1014486	103	82.73	2029	52	229	457	-
†† 83	1014501	119	95.13	2334	66	254	508	-
†† 89	1014529	126	101	2483	91	305	610	-
†† 95	1015051	152	122	2990	90	254	508	-
†† 102	1015060	169	135	3319	103	254	508	-
†† 108	1015067	160	128	3150	137	305	610	-
†† 121	1015079	163	130	3204	156	356	711	-
†† 121	1015088	176	141	3462	198	356	711	-
†† 127	1015094	179	143	3515	234	381	762	-

* Based on single leg sling (in-line load), or resultant load on multiple legs with an included angle less than or equal to 120 degrees.

** Proof test load equals or exceeds the requirement of ASTM A957(8.1) and ASME B30.9-1.4 for the chain size and number of legs. For use with chain slings, see page 166.

†† Welded Master Link.

COLD-TUFF® Fittings



A-342CT



- Alloy Steel - Quenched and Tempered
- Individually proof tested at 2 times Working Load Limit with certification.
- Certified to meet charpy impact testing of 42 J min. ave. at -20° C.
- Individually serialized and all certification shipped with each link.
- Links are certified in accordance with DNV specification 2.7-1-Offshore Containers and DNV rules for Lifting Appliances - Loose Gear.
- Finish is Inorganic Zinc Primer.

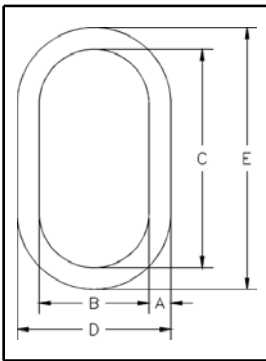

A-342CT Master Links

Size (mm)	A-342CT Stock No.	Working Load Limit (t)*	Weight Each (kg)	Dimensions (mm)					Deformation Indicator
				A	B	C	D	E	
31.8	1261401	15.9	4.42	31.8	111	222	175	286	140
38.1	1261412	21.7	7.77	38.1	133	267	210	343	165
44.5	1261423	28.3	11.8	44.5	152	305	241	394	191
51.0	1261433	44.3	18.7	51.0	178	356	279	457	229

* Minimum Ultimate Load is 5 times the Working Load Limit.

A-345CT

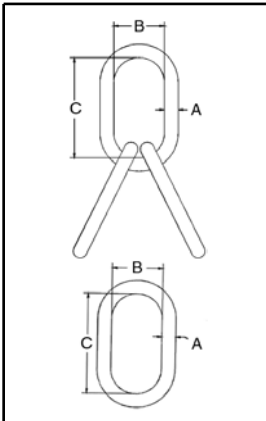

A-345CT Master Link Assembly

- Alloy Steel - Quenched and Tempered
- Individually proof tested at 2 times Working Load Limit with certification.
- Links are certified in accordance with DNV specification 2.7-1-Offshore Container and DNV rules for Lifting Appliances - Loose Gear.
- Certified to meet charpy impact testing of 42 J min. ave. at -20° C.
- Finish is Inorganic Zinc Primer.

Size (mm)	A-345CT Stock No.	Working Load Limit (t)*	Weight Each (kg)	Dimensions (mm)		
				A	B	C
31.8	1261609	15.9	13.6	31.8	111	222
38.1	1261620	21.7	23.1	38.1	133	267
44.5	1261631	28.3	35.4	44.5	152	305
51.0	1261642	44.3	56	51.0	178	356

* Minimum Ultimate Load is 5 times the Working Load Limit.

Links and Rings



G-340 S-340



G-340 from 16mm thru 22mm meet the performance requirements of Federal Specification RRC-271D, Type XV, except for those provisions required of the contractor.

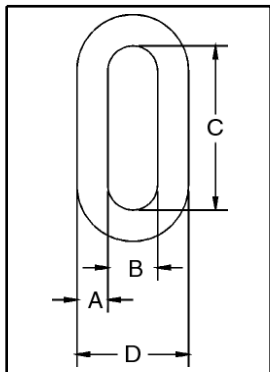

Weldless End Links

- Self Colored or Hot Dip galvanized.
- Forged carbon steel - Quenched and Tempered

Size (A) (mm)	Stock No.		Working Load Limit (t)*	Weight Each (kg)	Dimensions (mm)		
	G-340 Galv.	S-340 S.C.			B	C	D
8	1014057	1014066	1.13	.07	12.7	44.5	30.0
9-10	1014075	1014084	1.72	.10	14.2	47.8	35.1
11-13	1014093	1014100	2.95	.22	19.1	60.5	46.0
16	1014119	1014128	4.22	.44	25.4	82.5	59.0
18-20	1014137	1014146	6.35	.68	28.7	89.0	68.0
22	1014155	1014164	5.44	1.17	51.0	130	95.5
24-26	1014173	1014182	6.89	1.79	57.0	146	108
32	1014191	1014208	11.97	3.31	63.5	178	127
35	1014217	1014226	13.61	4.71	70.0	197	140

* Ultimate Load is 5 times the Working Load Limit. Based on single leg sling (in-line load), or resultant load on multiple legs with an included angle less than or equal to 120°.



S-643



Weldless Rings meet the performance requirements of Federal Specification RRC-271D Type VI, except for those provisions required of the contractor.

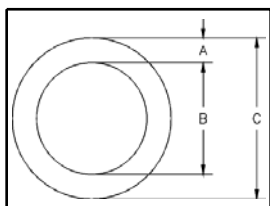

S-643 Weldless Rings

- Self Colored
- Forged carbon steel - Quenched and Tempered.

Size (A) (mm)	S-643 Stock No.	Working Load Limit Single Pull (t)*	Weight Each (kg)	Dimensions (mm)	
				B	C
22.2 x 102	1013780	3.27	1.23	102	146
22.2 x 140	1013806	2.54	1.57	140	184
25.4 x 102	1013824	4.90	1.67	102	152
28.6 x 152	1013842	4.72	2.99	152	210
31.8 x 127	1013860	7.71	3.09	127	191
34.9 x 152	1013888	8.62	4.59	152	222

* Ultimate Load is 6 times the Working Load Limit.

Pear Shaped Links



A-341



- Alloy Steel - Quenched and Tempered
- Individually Proof Tested at 2 times Working Load Limit with certification.
- Proof Test certification shipped with each link.
- Sizes 13mm, 16mm, 19mm, and 25mm are drop forged.

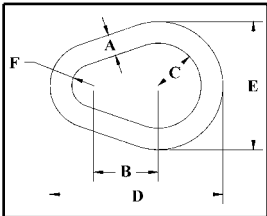

A-341 Alloy Pear Shaped Links

Stock Size (A) (mm)	A-341 Stock No.	Working Load Limit (t)*	Weight Each (kg)	Dimensions (mm)				
				B	C	D	E	F
13	1013575	3.15	.25	38.1	25.4	102	76.2	12.7
16	1013584	4.09	.50	47.8	31.8	127	95.3	16.0
19	1013595	5.59	.80	57.0	38.1	152	114	19.1
††22	1013604	6.36	1.28	67.0	44.5	178	133	22.4
25	1013613	11.0	1.91	76.0	51.0	203	152	25.4
††28	1013622	13.9	2.83	86.0	57.0	222	171	28.7
††32	1013631	16.4	3.74	95.5	63.5	254	191	31.8
††35	1013640	19.5	5.10	105	70.0	279	210	35.1
††38	1013649	24.7	6.46	114	76.0	305	229	38.1
††42	1013658	28.4	8.39	124	82.5	330	248	41.4
††44	1013667	38.6	10.2	133	89.0	356	267	44.5
††48	1013676	43.5	13.2	143	95.5	381	286	47.8
††51	1013685	46.6	15.4	152	102	406	305	51.0
††57	1013694	65.0	21.8	171	114	457	343	57.0
††64	1013703	66.9	29.9	191	127	508	381	63.5
††70	1013712	98.6	39.9	210	140	559	419	70.0
††76	1013721	103	52	229	152	610	457	76.0
††83	1013730	119	66	248	165	660	495	82.5
††89	1013739	126	82	267	178	711	533	89.0
††102	1013748	169	123	305	203	813	610	102

* Based on single leg sling (in-line load), or resultant load on multiple legs with an included angle less than or equal to 120°. Minimum Ultimate load is 5 times the Working Load Limit.

†† Welded Master Link.

G-341 / S-341

- Self Colored or Hot Dip galvanized.
- Forged carbon steel - Quenched and Tempered.

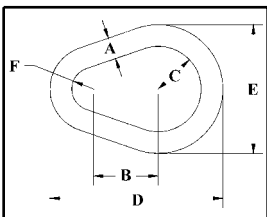

G-341 S-341 Weldless Sling Links

Size (A) (mm)	Stock No.		Working Load Limit Single Pull (t)*	Weight Each (kg)	Dimensions (mm)				
	G-341 Galv.	S-341 S.C.			B	C	D	E	F
9-10	1013897	1013904	.82	0.10	28.7	19.1	76.0	57.0	9.65
11-13	1013913	1013922	1.32	.25	38.1	25.4	102	76.0	12.7
16	1013931	1013940	1.91	.48	47.5	31.8	127	95.5	16.0
18-20	1013959	1013968	2.72	.85	57.0	38.1	152	114	19.1
22	1013977	1013986	3.76	1.25	67.0	44.5	178	133	22.4
24-26	1013995	1014002	4.90	1.97	76.0	51.0	203	152	25.4
32	1014011	1014020	7.60	3.45	102	63.5	260	191	31.8
35	1014039	1014048	9.30	5.13	105	70.0	279	210	35.1

* Ultimate Load is 6 times the Working Load Limit. Based on single leg sling (in-line load), or resultant load on multiple legs with an included angle less than or equal to 120°.

Rigging Accessories

Forged Eye Bolts



Fatigue Rated



SEE APPLICATION AND WARNING INFORMATION

On Pages 154-155

G-291



- Recommended for straight line pull.
- All Bolts Hot Dip galvanized after threading (UNC).
- Furnished with standard Hot Dip galvanized hex nuts.
- Forged Steel - Quenched and Tempered.
- Fatigue rated at 1-1/2 times the Working Load Limit at 20,000 cycles.

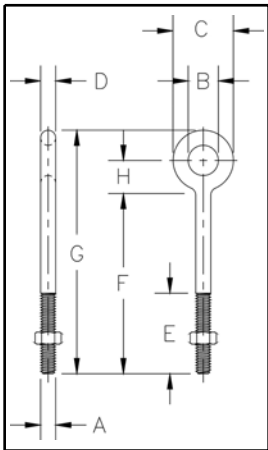

G-291 Regular Nut Eye Bolts

Shank Dia. & Length (mm)	G-291 Stock No.	Working Load Limit (t)*	Weight Per 100 (kg)	Dimensions (mm)							
				A	B	C	D	E	F	G	H
6.35 x 51.0	1043230	.29	3.72	6.35	12.7	25.4	6.35	38.1	51.0	77.5	14.2
6.35 x 102	1043258	.29	5.31	6.35	12.7	25.4	6.35	63.5	102	129	14.2
7.94 x 57.0	1043276	.54	6.03	7.85	15.7	31.8	7.85	38.1	57.0	90.5	17.5
7.94 x 108	1043294	.54	11.3	7.85	15.7	31.8	7.85	63.5	108	141	17.5
9.53 x 63.5	1043310	.70	10.6	9.65	19.1	38.1	9.65	38.1	63.5	105	22.4
9.53 x 114	1043338	.70	13.4	9.65	19.1	38.1	9.65	63.5	114	155	22.4
9.53 x 152	1043356	.70	16.0	9.65	19.1	38.1	9.65	63.5	152	194	22.4
12.7 x 82.5	1043374	1.18	22.8	12.7	25.4	51.0	12.7	38.1	82.5	137	28.4
12.7 x 152	1043392	1.18	30.0	12.7	25.4	51.0	12.7	76.0	152	206	28.4
12.7 x 203	1043418	1.18	37	12.7	25.4	51.0	12.7	76.0	203	257	28.4
12.7 x 254	1043436	1.18	40	12.7	25.4	51.0	12.7	76.0	254	308	28.4
12.7 x 305	1043454	1.18	52	12.7	25.4	51.0	12.7	76.0	305	359	28.4
15.9 x 102	1043472	2.35	47	15.7	31.8	63.5	15.7	51.0	102	170	36.6
15.9 x 305	1043490	2.35	54	15.7	31.8	63.5	15.7	76.0	152	221	36.6
15.9 x 203	1043515	2.35	61	15.7	31.8	63.5	15.7	76.0	203	272	36.6
15.9 x 254	1043533	2.35	70	15.7	31.8	63.5	15.7	76.0	254	322	36.6
15.9 x 305	1043551	2.35	76	15.7	31.8	63.5	15.7	102	305	373	36.6
19.1 x 114	1043579	3.26	76	19.1	38.1	76.0	19.1	51.0	114	195	42.9
19.1 x 152	1043597	3.26	84	19.1	38.1	76.0	19.1	76.0	152	233	42.9
19.1 x 203	1043613	3.26	94	19.1	38.1	76.0	19.1	76.0	203	284	42.9
19.1 x 254	1043631	3.26	107	19.1	38.1	76.0	19.1	76.0	254	335	42.9
19.1 x 305	1043659	3.26	117	19.1	38.1	76.0	19.1	102	305	386	42.9
19.1 x 381	1043677	3.26	135	19.1	38.1	76.0	19.1	127	381	462	42.9
22.2 x 127	1043695	4.80	122	22.4	44.5	89.0	22.4	63.5	127	222	51.0
22.2 x 203	1043711	4.80	140	22.4	44.5	89.0	22.4	102	203	298	51.0
22.2 x 305	1043739	4.80	181	22.4	44.5	89.0	22.4	102	305	400	51.0
25.4 x 152	1043757	6.03	191	25.4	51.0	102	25.4	76.0	152	262	58.5
25.4 x 229	1043775	6.03	213	25.4	51.0	102	25.4	102	229	338	58.5
25.4 x 305	1043793	6.03	245	25.4	51.0	102	25.4	102	305	414	58.5
25.4 x 457	1043819	6.03	295	25.4	51.0	102	25.4	178	457	567	58.5
31.8 x 203	1043837	9.52	340	31.8	63.5	127	31.8	102	203	340	73.0
31.8 x 305	1043855	9.52	408	31.8	63.5	127	31.8	102	305	441	73.0
31.8 x 508	1043873	9.52	549	31.8	63.5	127	31.8	152	508	645	73.0

* Ultimate Load is 5 times the Working Load Limit. Working Load Limit shown is for in-line pull. Maximum Proof Load is 2 times the Working Load Limit.

Forged Eye Bolts



Fatigue Rated

SEE APPLICATION AND WARNING INFORMATION
On Pages 154-155

G-277



- Forged Steel.
- All Bolts Hot Dip galvanized after threading (UNC).
- Furnished with standard Hot Dip galvanized, heavy hex nuts.
- Fatigue rated at 1-1/2 times the Working Load Limit at 20,000 cycles.

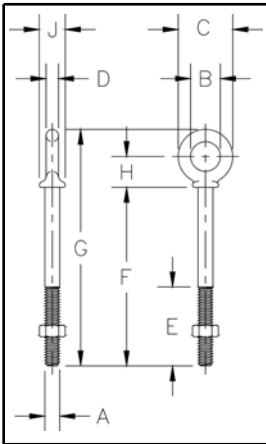

G-277 Shoulder Nut Eye Bolts

Shank Diameter & Length (mm)	G-277 Stock No.	Working Load Limit (t)*	Weight Per 100 (kg)	Dimensions (mm)								
				A	B	C	D	E	F	G	H	J
6.35 x 51.0	1045014	.29	2.99	6.35	12.7	22.4	4.85	38.1	51.0	74.5	12.7	11.9
6.35 x 102	1045032	.29	4.13	6.35	12.7	22.4	4.85	63.5	102	125	12.7	11.9
7.94 x 57.0	1045050	.54	5.67	7.85	15.7	28.4	6.35	38.1	57.0	89.0	17.5	14.2
7.94 x 108	1045078	.54	8.53	7.85	15.7	28.4	6.35	63.5	108	140	17.5	14.2
9.53 x 63.5	1045096	.70	9.71	9.65	19.1	35.1	7.85	38.1	63.5	101	19.8	16.8
9.53 x 114	1045112	.70	11.5	9.65	19.1	35.1	7.85	63.5	114	152	19.8	16.8
12.7 x 82.5	1045130	1.18	19.3	12.7	25.4	44.5	9.65	38.1	82.5	130	25.4	23.1
12.7 x 152	1045158	1.18	25.8	12.7	25.4	44.5	9.65	76.0	152	200	25.4	23.1
15.9 x 102	1045176	2.35	31.1	15.7	31.8	57.0	12.7	51.0	102	164	33.3	28.4
15.9 x 305	1045194	2.35	46.4	15.7	31.8	57.0	12.7	76.0	152	214	33.3	28.4
19.1 x 114	1045210	3.26	66	19.1	38.1	70.0	15.7	51.0	114	189	39.6	35.1
19.1 x 152	1045238	3.26	76	19.1	38.1	70.0	15.7	76.0	152	227	39.6	35.1
22.2 x 127	1045256	4.80	102	22.4	44.5	82.5	19.1	63.5	127	215	46.7	39.6
25.4 x 152	1045292	6.03	166	25.4	51.0	95.5	22.4	76.0	152	253	53.0	46.0
25.4 x 229	1045318	6.03	192	25.4	51.0	95.5	22.4	102	229	329	53.0	46.0
31.8 x 203	1045336	9.52	295	31.8	63.5	114	25.4	102	203	323	62.5	58.0
31.8 x 305	1045354	9.52	361	31.8	63.5	114	25.4	102	305	425	62.5	58.0
38.1 x 381	1045372	10.8	646	38.1	76.0	140	31.8	152	381	527	76.0	70.0

* Ultimate Load is 5 times the Working Load Limit. Working Load Limit shown is for in-line pull. Maximum Proof Load is 2 times the Working Load Limit.

Rigging Accessories



G-275



- Forged Steel — Quenched and Tempered.
- Hot Dip galvanized.

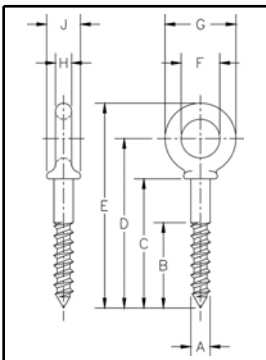

G-275 Screw Eye Bolts

Shank Diameter & Length (mm)	G-275 Stock No.	Weight Per 100 (kg)	Dimensions (mm)								
			A	B	C	D	E	F	G	H	J
6.35 x 51.0	1046111	1.95	6.35	38.1	51.0	63.5	74.5	12.7	22.4	4.83	11.9
7.94 x 57.0	1046139	4.49	7.85	42.9	57.0	74.5	89.0	16.0	28.7	6.35	14.2
9.53 x 63.5	1046157	8.56	9.65	47.8	63.5	83.5	101	19.1	35.1	7.87	16.8
12.7 x 82.5	1046175	17.0	12.7	62.0	82.5	108	130	25.4	44.5	9.65	23.1
15.9 x 102	1046193	38.8	16.0	76.0	102	135	164	31.8	57.0	12.7	28.4

Forged Machinery Eye Bolts



Fatigue Rated



SEE APPLICATION AND WARNING INFORMATION

On Pages 154-155

S-279 / M-279



- Forged Steel - Quenched & Tempered.
- Working Load Limits shown are for In-line pull.
- Recommended for straight line pull.
- Fatigue rated at 1-1/2 times the Working Load Limit at 20,000 cycles.
- S-279 threaded UNC.
- M-279 metric threaded.

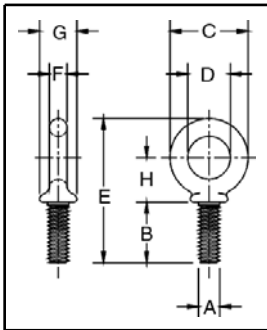

Shoulder Type Machinery Eye Bolts

S-279 UNC

Size	S-279 Stock No.	Working Load Limit (t)*	Weight Each (kg)	Dimensions (mm)						
				A** Thread	B	C	D	E	F	G
6.35 x 25.4	9900182	.29	.02	1/4 - 20	25.9	28.7	19.1	58.0	4.85	13.5
7.94 x 28.6	9900191	.54	.04	5/16 - 18	29.2	35.1	22.4	69.5	6.35	15.0
9.53 x 31.8	9900208	.70	.06	3/8 - 16	32.3	41.1	25.4	78.0	7.85	17.5
12.7 x 38.1	9900217	1.18	.12	1/2 - 13	38.9	49.5	30.2	94.0	9.65	23.1
15.9 x 44.5	9900226	2.35	.24	5/8 - 11	45.5	60.5	35.1	113	12.7	28.7
19.1 x 51.0	9900235	3.26	.43	3/4 - 10	52.0	70.0	38.1	129	16.0	35.1
22.2 x 57.0	9900244	4.08	.70	7/8 - 9	58.5	82.5	44.5	149	19.1	39.6
25.4 x 63.5	9900253	6.03	1.1	1 - 8	65.5	95.5	51.0	169	22.4	46.0
31.8 x 76.0	9900262	9.52	1.8	1-1/4 - 7	78.5	114	63.5	202	25.4	58.0
38.1 x 89.0	9900271	10.8	3.2	1-1/2 - 6	91.5	140	76.0	241	31.8	70.0

* Ultimate Load is 5 times the Working Load Limit. Maximum Proof Load is 2 times the Working Load Limit.

** All bolts threaded UNC.

M-279 Metric

Size	M-279 Stock No.	Working Load Limit (kg)*	Weight Each (kg)	Dimensions (mm)						
				A** Thread	B	C	D	E	F	G
M6	10457534	200	.03	6	13.0	28.7	19.1	58.0	4.9	13.5
M8	10457894	400	.05	8	13.0	35.1	22.4	59.7	6.4	15.0
M10	10458334	640	.08	10	17.0	41.1	25.4	78.0	7.9	17.5
M12	10458694	1000	.18	12	20.5	49.5	30.2	94.0	9.7	23.1
M16	10459134	1800	.40	16	27.0	60.5	35.1	113	12.7	28.7
M20	10459954	2500	.90	20	30.0	70.0	38.1	129	16.0	35.1
M24	10460294	4000	.95	27	36.0	95.5	51.0	169	22.4	46.0
M30	10460754	6000	1.6	30	45.0	114	53.5	202	25.4	58.0
M36	10461094	8500	2.7	36	54.0	140	76.0	241	31.8	70.0

* Ultimate Load is 5 times the Working Load Limit. Maximum Proof Load is 2 times the Working Load Limit.

** On Request: Special threading or as forged bolts for customer conversion.

Forged Rivet Eye Bolts



S-293

- Forged Steel — Quenched and Tempered.

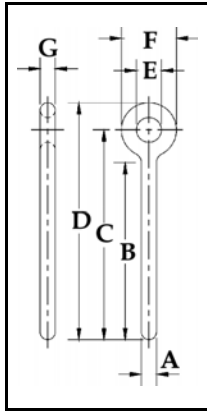

S-293 Rivet Eye Bolts

Shank Diameter & Length (mm)	S-293 Stock No.	Weight Per 100 (kg)	Dimensions (mm)						
			A	B	C	D	E	F	G
6.35 x 51.0	1043882	2.85	6.35	51.0	67.0	79.5	12.7	25.4	6.35
6.35 x 102	1043908	5.12	6.35	102	118	130	12.7	25.4	6.35
7.94 x 57.0	1043926	5.44	7.94	57.0	76.0	92.0	16.0	31.8	7.87
7.94 x 108	1043944	8.30	7.94	108	127	143	16.0	31.8	7.87
9.53 x 63.5	1043962	11.33	9.53	63.5	86.0	104	19.1	38.1	9.65
9.53 x 114	1043980	12.51	9.53	114	137	155	19.1	38.1	9.65
9.53 x 152	1044006	14.28	9.53	152	175	193	19.1	38.1	9.65
12.7 x 82.5	1044024	19.86	12.7	82.5	111	136	25.4	51.0	12.7
12.7 x 152	1044042	28.34	12.7	152	181	206	25.4	51.0	12.7
15.9 x 102	1044060	42.5	15.9	102	140	171	31.8	63.5	15.8
15.9 x 152	1044088	51.2	15.9	152	190	222	31.8	63.5	15.8
19.1 x 114	1044104	65.2	19.1	114	159	196	38.1	76.0	19.1
19.1 x 152	1044122	73.7	19.1	152	197	234	38.1	76.0	19.1
22.2 x 127	1044140	108	22.2	127	178	222	44.5	89.0	22.2
22.2 x 203	1044168	132	22.2	203	254	298	44.5	89.0	22.2
25.4 x 152	1044186	170	25.4	152	213	263	51.0	102	25.4
25.4 x 229	1044202	204	25.4	229	289	339	51.0	102	25.4
31.8 x 203	1044220	327	31.8	203	279	340	63.0	127	31.8
31.8 x 305	1044248	388	31.8	305	378	441	63.0	127	31.8

Rigging Accessories



S-276

- Forged Steel — Quenched and Tempered.

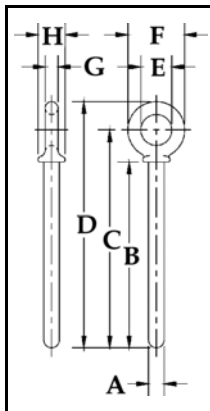

S-276 Shoulder Rivet Eye Bolts

Shank Diameter & Length (mm)	S-276 Stock No.	Weight Per 100 (kg)	Dimensions (mm)							
			A	B	C	D	E	F	G	H
6.35 x 51.0	1045746	2.49	6.35	51.0	63.5	74.5	12.7	22.4	4.85	11.9
6.35 x 102	1045764	3.18	6.35	102	114	125	12.7	22.4	4.85	11.9
7.94 x 57.0	1045782	2.86	7.85	57.0	74.5	89.0	16.0	33.3	6.35	14.2
7.94 x 108	1045808	6.71	7.85	108	125	140	16.0	28.7	6.35	14.2
9.53 x 63.5	1045826	8.53	9.65	63.5	83.5	101	19.1	35.1	7.85	16.8
9.53 x 114	1045844	11.3	9.65	114	134	152	19.1	35.1	7.85	16.8
12.7 x 82.5	1045862	15.0	12.7	82.5	108	130	25.4	44.5	9.65	23.1
12.7 x 152	1045880	22.7	12.7	152	178	200	25.4	44.5	9.65	23.1
15.9 x 102	1045906	31.2	16.0	102	135	164	31.8	57.0	12.7	28.4
15.9 x 305	1045924	34.0	16.0	152	186	214	31.8	57.0	12.7	28.4
19.1 x 114	1045942	57	19.1	114	154	189	38.1	70.0	15.7	35.1
19.1 x 152	1045960	68	19.1	152	192	227	38.1	70.0	15.7	35.1
22.2 x 127	1045988	91	22.4	127	174	215	44.5	82.5	19.1	39.6
25.4 x 152	1046022	135	25.4	152	205	253	51.0	95.5	22.4	46.0
25.4 x 229	1046040	193	25.4	229	282	329	51.0	95.5	22.4	46.0
31.8 x 203	1046068	297	31.8	203	266	323	63.5	114	25.4	58.0
31.8 x 305	1046086	323	31.8	305	368	425	63.5	114	25.4	58.0
38.1 x 381	1046102	646	38.1	381	457	527	76.0	140	31.8	70.0

Ring Bolts - Pad Eyes



G-257



- Forged Steel - Quenched and Tempered.
- Diameter of ring stock is same as shank diameter.
- Hot Dip galvanized.
- All Bolts Hot Dip galvanized after threading.

**G-257
Shoulder Nut Ring Bolts**

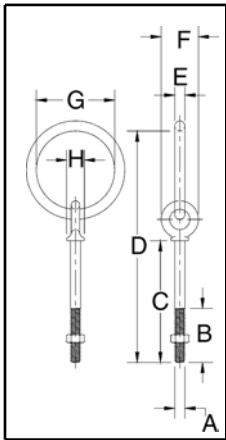

Ring Bolt Size (mm)	G-257 Stock No.	Working Load Limit (t)*	Weight Per 100 (kg)	Dimensions (mm)							
				A	B	C	D	E	F	G	H
9.53 X 114	1046335	.54	25.7	9.65	63.5	114	195	9.70	35.1	51.0	16.8
12.7 X 152	1046371	1.00	45.4	12.7	76.0	152	254	12.7	44.5	63.5	23.1

* Ultimate Load is 5 times the Working Load Limit.



S-264



- Forged Steel — Quenched and Tempered.
- Forged from 1035 Carbon Steel.
- Excellent welding qualities.
- Widely used on farm machinery, trucks, steel hulled marine vessels and material handling equipment.
- Reference American Welding Society specifications for proper welding procedures.

**S-264
Pad Eyes**

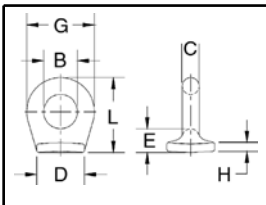

Size No.:	S-264 Stock No.	Weight Per 100 (kg)	Dimensions (mm)						
			B	C	D	E	G	H	L
* 0	1090722	1.27	6.35	4.85	16.0	7.85	16.0	2.30	19.1
* 1	1090740	2.95	9.65	6.35	22.4	10.4	22.4	3.30	26.2
* 1	1090768	4.72	16.0	6.35	25.4	11.2	28.7	4.05	33.3
2	1090786	9.57	19.1	9.65	26.9	12.7	38.1	4.85	41.4
4	1090802	23.7	25.4	14.2	36.6	19.8	54.0	5.60	59.5
5	1090820	37.4	31.8	17.5	44.5	20.6	67.0	6.35	70.0

* Meets the requirements of Military Specification MS-51930A.

Forged Eye Nuts



G-400



- Forged Steel - Quenched and Tempered.
- Hot Dip galvanized.
- Tapped with standard UNC class 2 threads after galvanizing.
- Available also in blank (as forged) item (S-4028) or on request with metric threading (M-4028)

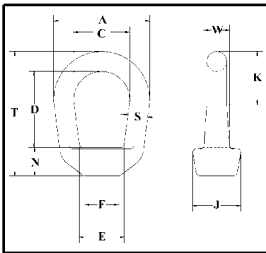

G-400 Eye Nuts

Size No.	"S" Stock Size (mm)	G-400 Stock No.	Std. Tap Size (in.)	Working Load Limit (t)*	Weight Each (kg)	Dimensions (mm)									
						A	C	D	E	F	J	K	N	T	W
1	6.35	1090438	1/4	.24	.04	31.8	19.1	25.4	19.1	12.7	17.5	16.0	11.7	43.7	7.85
2	7.85	1090474	3/8	.57	.08	41.1	25.4	30.5	21.1	14.2	20.6	22.6	14.7	53	10.4
3A	9.65	1090517	1/2	1.02	.13	51.0	31.8	36.6	27.4	20.6	25.4	27.7	18.5	63.5	12.7
4	12.7	1090535	5/8	1.63	.27	63.5	38.1	48.8	34.3	25.4	33.3	33.3	21.1	82.5	17.5
5	16	1090553	3/4	2.36	.45	76.0	44.5	58.0	40.4	28.4	38.1	39.9	26.7	100	21.3
6	19.1	1090571	7/8	3.27	.75	89.0	51.0	63.5	49.8	35.1	47.8	45.0	29.0	111	25.4
7	22.4	1090599	1	4.54	1.22	102	57.0	74.0	56.0	39.6	54.0	51.5	33.0	129	30.2
8	25.4	1090633	1-1/4	7.03	1.76	114	63.5	85.0	62.5	47.8	60.5	57.5	38.6	149	35.1
9	28.7	1090651	1-3/8	8.39	2.27	127	70.0	102	68.5	51.0	65.0	64.5	42.4	165	38.1
10	31.8	1090679	1-1/2	10.21	3.08	143	79.0	109	78.5	57.0	76.0	71.5	46.5	179	42.2
11	38.1	1090697	2	18.14	6.62	181	104	152	104	79.5	95.5	93.5	63.0	257	49.3

* Ultimate Load is 5 times the Working Load Limit. Rating based on standard tap size.

Rigging Accessories



S-405



- Forged Steel - Quenched and Tempered.
- On request: threaded to customer specification.
-

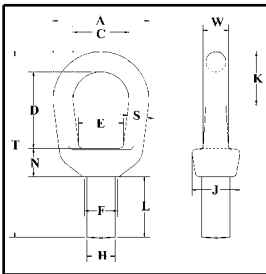

S-405 Lifting Eyes

Size No.	S-405 Stock No.	Working Load Limit Threaded (t)*	Weight Each (kg)	Dimensions (mm)											
				A	C	D	E	F	H	J	K	L	N	T	W
1	1090269	.39	.05	31.8	19.1	25.9	16.8	12.7	8.65	17.5	17.0	17.5	10.7	62.5	7.85
2	1090287	.57	.09	41.1	25.4	30.5	19.1	14.2	10.4	20.6	23.4	23.9	14.0	76	10.4
3	1090303	1.02	.23	51.0	31.8	36.6	25.4	20.6	13.5	28.7	28.7	31.8	17.3	93.5	12.7
4	1090321	1.63	.36	63.5	38.1	48.8	30.2	25.4	16.8	33.3	35.1	38.1	20.3	116	17.5
5	1090349	2.36	.57	76.0	44.5	58.0	35.1	28.4	19.8	38.1	42.2	44.5	24.9	140	21.3
6	1090367	3.27	1.02	89.0	51.0	63.5	41.4	35.1	23.1	47.8	48.5	47.8	26.9	156	25.4
7	1090385	4.54	1.47	102	57.0	74.0	47.8	39.6	26.2	54.0	55.0	52.5	30.5	179	30.2
8	1090401	5.67	2.13	114	63.5	85.0	49.3	47.8	29.5	60.5	62.5	63.5	35.6	207	35.1
10	1090410	8.16	4.23	143	79.0	97.0	70.0	57.0	42.2	76.0	75.5	81.5	42.9	252	42.2

* Ultimate Load is 5 times the Working Load Limit. Rating based on UNC thread size shown in column "H".

Swivel Hoist Ring

Color coded to distinguish between UNC (Red) and Metric (Silver) thread types.



U.S. Patent 5,352,056



Load Rated

HR-125 M
Patented

Fatigue Rated

HR-125
Patented

- Rated at 100% at 90° angle
- Each product has a Product Identification Code (PIC) for material traceability along with a Working Load Limit and the name Crosby or "CG" stamped into it.
- All components are Alloy Steel - Quenched and Tempered.
- Available in UNC and Metric thread sizes.
- UNC threads available in sizes from 800 pounds to 30,000 pounds Working Load Limit, with a design factor of 5 to 1.
- Metric threads available in sizes from 400 kg to 16,900 kg and dual rated in both a 4 to 1 and 5 to 1 design factor.
- 360° swivel and 180° pivot action.
- 100% individually proof tested to 2-1/2 times the Working Load Limit with certification and Statistically Magnetic Particle inspected. (Can be furnished 100% Magnetic Particle inspected when requested at time of order).
- Fatigue rated to 20,000 cycles at 1-1/2 times the Working Load Limit.
- Individually packaged along with proper application instructions and warning information.
- Bolt is secured with patented retaining ring which requires no modification to threads. This method allows for easy disassembly and assembly of hoist ring for thorough examination of all components. Replacement kits are available.
- Bolts are individually Proof Tested.
- Multiple Bolt lengths available to meet specific application requirements.

UNC Swivel Hoist Rings

SEE APPLICATION AND WARNING INFORMATION

Para Español: www.thecrosbygroup.com On Pages 156-157

HR-125



- Top washer has the following features:
- The Working Load Limit and Recommended Torque value are permanently stamped into each washer.
- Washer is color coded for easy identification: Red - UNC thread.
- Bolt specification is a Grade 8 Alloy socket head cap screw to ASTM A 574. All threads listed are UNC.
- BOLT SIZE IDENTIFICATION: The size of the bolt will be stated as in the drawing below. Illustration shows meaning of each dimension given.
- NOTE: For Special Applications, see page 334.

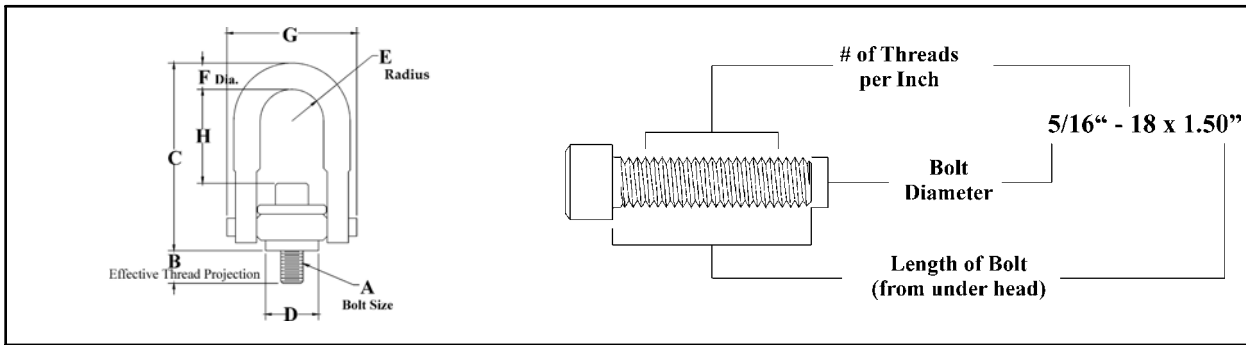

HR-125 UNC Threads

Frame Size No.	HR-125 Stock No.	Working Load Limit (lbs.)*	Torque in Ft. Lbs.	Dimensions (in.)								Weight Each (lbs.)
				Bolt Size A ‡	Effective Thread Projection Length B	C	D	Radius E	Diameter F	G	H	
1 †	1016887	800	7	5/16 - 18 x 1.50	.59	2.69	.94	.46	.34	1.69	1.11	43
1 †	1016898	1000	12	3/8 - 16 x 1.50	.59	2.69	.94	.46	.34	1.69	1.09	43
2	1016909	2500	28	1/2 - 13 x 2.00	.71	4.82	2.00	.88	.69	3.30	2.29	249
2 †	1016912	2500	28	1/2 - 13 x 2.50	1.21	4.82	2.00	.88	.69	3.30	2.29	252
2	1016920	4000	60	5/8 - 11 x 2.00	.71	4.82	2.00	.88	.69	3.30	2.21	255
2 †	1016924	4000	60	5/8 - 11 x 2.75	1.46	4.82	2.00	.88	.69	3.30	2.21	270
2	1016931	5000	100	3/4 - 10 x 2.25	.96	4.82	2.00	.88	.69	3.30	2.05	265
2 †	1016935	5000	100	3/4 - 10 x 2.75	1.46	4.82	2.00	.88	.69	3.30	2.05	300
3	1016942	7000	100	3/4 - 10 x 2.75	.90	6.55	3.00	1.37	.94	4.73	2.98	700
3 †	1016946	7000	100	3/4 - 10 x 3.50	1.65	6.55	3.00	1.37	.94	4.73	2.98	700
3	1016953	8000	160	7/8 - 9 x 2.75	.90	6.55	3.00	1.37	.94	4.73	2.85	700
3 †	1016957	8000	160	7/8 - 9 x 3.50	1.65	6.55	3.00	1.37	.94	4.73	2.85	700
3	1016964	10000	230	1 - 8 x 3.00	1.15	6.55	3.00	1.37	.94	4.73	2.73	750
3 †	1016969	10000	230	1 - 8 x 4.00	2.15	6.55	3.00	1.37	.94	4.73	2.73	750
4	1016975	15000	470	1-1/4 - 7 x 4.50	2.22	8.70	3.75	1.69	1.19	6.00	3.92	1479
5	1016986	24000	800	1-1/2 - 6 x 6.50	2.98	12.39	4.75	2.25	1.69	8.00	5.94	3300
5	1016997	30000	1100	2 - 4-1/2 x 6.50	2.98	12.39	4.75	2.25	1.69	8.00	5.14	3600
6	1017001	50000	2100	2-1/2 - 4 x 8.00	4.00	16.88	5.75	3.00	2.25	11.69	8.00	8800
7	1017005	75000	4300	3 - 4 x 10.50	5.20	19.50	7.25	3.75	2.75	14.12	8.50	165.00
8	1017009	100000	6600	3-1/2 - 4 x 13.00	7.00	22.06	7.75	4.00	3.25	16.00	9.25	240.00

* Ultimate Load is 5 times the Working Load Limit.

† Long Bolts are designed to be used with soft metal (i.e., aluminum) work piece. While the long bolts may also be used with ferrous metal (i.e., steel & iron) work piece, short bolts are designed for ferrous work pieces only.

‡ Bolt specification is a Grade 8 Alloy socket head cap screw to ASTM A 574.

Rigging Accessories

Metric Swivel Hoist Rings



SEE APPLICATION AND WARNING INFORMATION

Para Español: www.thecrosbygroup.com

On Pages 156-157

HR-125M



- Top washer has the following features:
- The Working Load Limit and Recommended Torque value are permanently stamped into each washer.
- Washer is color coded for easy identification: Silver - Metric thread.
- Bolt specification is a Grade 12.9 Alloy socket head cap screw to Din 912. All threads listed are metric (ASME/ ANSI B18.3.1m).
- Designed to be used with ferrous work piece only.
- BOLT SIZE IDENTIFICATION: The size of the bolt will be stated as in the drawing below. Illustration shows meaning of each dimension given.
- NOTE: For Special Applications, see page 334.

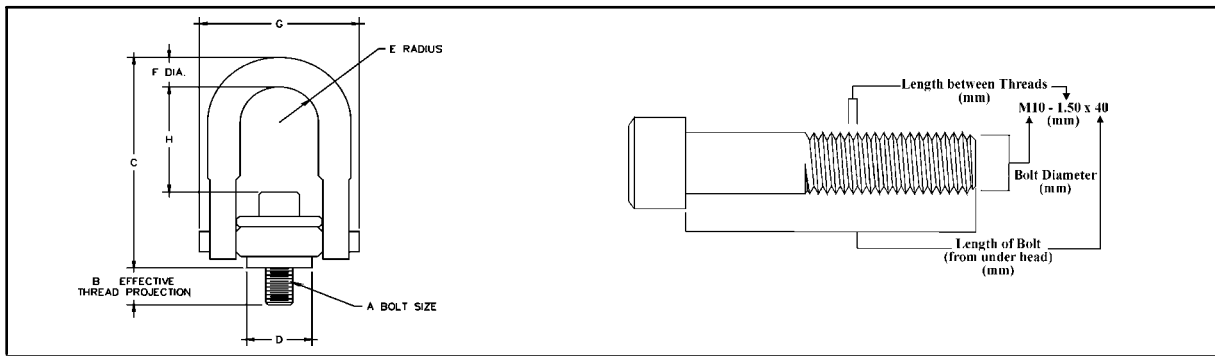

HR-125M Metric Threads

HR-125M Stock No.	Working Load Limit (kg)		Torque in Nm*	Dimensions (mm)								Weight Each (kg)
	At a 5:1 Design Factor †	At a 4:1 Design Factor †		(A) Bolt Size ‡	(B) Effective Thread Projection Length	C	D	Radius E	Dia. F	G	H	
1016602	400	500	10	M8X1.25X40	16.9	68.1	25.4	11.8	8.5	42.9	28.2	.19
1016613	450	550	16	M10X1.50X40	16.9	68.1	25.4	11.8	8.5	42.9	27.69	.19
1016624	1050	1300	38	M12X1.75X50	17.2	124.5	50.8	22.3	17.5	82.7	58.17	1.13
1016635	1900	2400	81	M16X2.00X60	27.2	124.5	50.8	22.3	17.5	82.7	56.13	1.22
1016644	2150	2700	136	M20X2.50X65	31.2	124.5	50.8	22.3	17.5	82.7	52.07	1.36
1016657	3000	3750	136	M20X2.50X75	28.1	167.0	76.2	34.7	25.4	120.1	75.69	3.18
1016668	4200	5250	312	M24X3.00X80	33.1	167.0	76.2	34.7	25.4	120.1	74.93	3.18
1016679	7000	8750	637	M30X3.50X120	65.1	231.5	96.3	44.5	30.5	152.4	69.34	6.70
1016690	11000	13750	1005	M36X4.00X150	60.6	315.3	120.7	57.2	44.5	203.2	124.20	14.95
1016701	12500	15600	1005	M42X4.50X160	70.6	315.3	120.7	57.2	44.5	203.2	150.62	16.33
1016712	13500	16900	1350	M48X5.00X160	70.6	315.3	120.7	57.2	44.5	203.2	137.92	16.33

* The tightening torque values shown are based upon threads being clean, dry and free of lubrication.

† Individually proof loaded to 2-1/2 times the Working Load Limit based on the 4:1 design factor.

‡ Bolt specification is a Grade 12.9 Alloy socket head cap screw to Din 912. All threads are metric (ASME/ ANSI B18.3.1m).

HR-1200 Side Pull Hoist Rings



SEE APPLICATION AND WARNING INFORMATION

On Pages 158-159

HR-1200 UNC AND METRIC



- Wide range of capacities available:
 - 650 lbs. to 29,000 lbs.
 - Metric sizes from 0.3 tonnes to 13 tonnes.
- Rated at 100% of Working Load Limit for angles up to 90 degrees.
- Utilize standard Crosby Red Pin® Shackles to connect to wire rope or synthetic slings. (sold separately)
- Multiple bolt lengths available to meet specific application requirements.
- Hoist Ring body is furnished with Yellow Chromate finish for improved corrosion resistance.
- Each product is stamped with a Product Identification Code (PIC), for material traceability, along with a Working Load Limit, and the name Crosby or "CG".
- Body components are Alloy Steel- Quenched and Tempered.

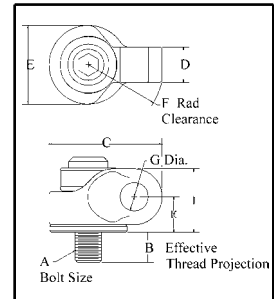

Rigging Accessories

HR-1200 UNC Sidepull Hoist Rings

Weight Each (lbs.)	Working Load Limit (lbs.) *	HR-1200 Stock No.	Hoist Ring Bolt Torque (Ft.Lbs.)	(A) Bolt Size	(B) Eff. Thread Proj. (in.)	Dimensions (in.)							Recommended Shackles			
						C	D	E	F	G	H	I	Red Pin® Shackles 209,210,213, 215,2130,2150		Red Pin Web Shackles S-281	
													Nominal Size (in.)	WLL (t)	Web Size (in.)	WLL (tons)
.35	650	1067700	7	5/16-18x1.50	.59	1.93	.72	1.00	1.56	.80	.85	1.43	1/2, 5/8	2, 3-1/4	2	3-1/4
.36	800	1067704	12	3/8-16x1.50	.59	1.93	.72	1.00	1.56	.80	.85	1.43	1/2, 5/8	2, 3-1/4	2	3-1/4
1.4	2000	1067708	28	1/2-13x2.00	.71	2.97	.97	2.00	2.13	.93	1.07	1.79	5/8, 3/4	3-1/4, 4-3/4	2, 1.5	3-1/4, 4-1/2
1.4	2000	1067712	28	1/2-13x2.50	1.21	2.97	.97	2.00	2.13	.93	1.07	1.79	5/8, 3/4	3-1/4, 4-3/4	2, 1.5	3-1/4, 4-1/2
1.5	3000	1067716	60	5/8-11x2.00	.71	2.97	.97	2.00	2.13	.93	1.07	1.79	5/8, 3/4	3-1/4, 4-3/4	2, 1.5	3-1/4, 4-1/2
1.5	3000	1067720	60	5/8-11x2.75	1.46	2.97	.97	2.00	2.13	.93	1.07	1.79	5/8, 3/4	3-1/4, 4-3/4	2, 1.5	3-1/4, 4-1/2
4.5	5000	1067724	100	3/4-10x2.75	.90	4.32	1.34	3.00	3.00	1.07	1.35	2.42	7/8	6-1/2	2	6-1/4
4.6	5000	1067728	100	3/4-10x3.50	1.65	4.32	1.34	3.00	3.00	1.07	1.35	2.42	7/8	6-1/2	2	6-1/4
4.6	6500	1067732	160	7/8-9x2.75	.90	4.32	1.34	3.00	3.00	1.07	1.35	2.42	7/8	6-1/2	2	6-1/4
4.8	6500	1067736	160	7/8-9x3.50	1.65	4.32	1.34	3.00	3.00	1.07	1.35	2.42	7/8	6-1/2	2	6-1/4
4.8	8000	1067740	230	1 -8x3.00	1.15	4.32	1.34	3.00	3.00	1.07	1.35	2.42	7/8	6-1/2	2	6-1/4
5.0	8000	1067744	230	1 -8x4.00	2.15	4.32	1.34	3.00	3.00	1.07	1.35	2.42	7/8	6-1/2	2	6-1/4
10.2	14000	1067748	470	1-1/4-7x4.5	2.22	5.59	1.57	3.75	3.91	1.47	1.92	3.42	1, 1-1/8, 1-1/4	8-1/2, 9-1/2, 12	3	8-1/2
23.5	17200	1067756	800	1-1/2-6x6.5	2.98	7.31	2.06	4.75	5.19	2.11	2.41	4.29	1-3/8, 1-1/2, 1-3/4	13-1/2, 17, 25	-	-
25.3	29000	1067764	1100	2 -4.5x6.5	2.98	7.31	2.06	4.75	5.19	2.11	2.41	4.29	1-3/8, 1-1/2, 1-3/4	13-1/2, 17, 25	-	-

HR-1200M Metric Sidepull Hoist Rings

Weight Each (kg)	Working Load Limit (kg)'	HR1200M Stock No.	Hoist Ring Bolt Torque (Nm)	(A) Bolt Size	(B) Eff. Thread Proj. (mm)	Dimensions (mm)							Recommended Shackles			
						C	D	E	F	G	H	I	Red Pin® Shackles 209,210,213, 215,2130,2150		Red Pin® Web Shackles S-281	
													Nominal Size (in.)	WLL (t)	Web Size (in.)	WLL (tons)
.18	300	1067803	10	M8x1.25x40	16.9	49.0	18.3	25.4	39.6	20.3	21.6	36.3	1/2, 5/8	2, 3-1/4	2	3-1/4
.18	400	1067807	16	M10x1.50x40	16.9	49.0	18.3	25.4	39.6	20.3	21.6	36.3	1/2, 5/8	2, 3-1/4	2	3-1/4
.63	1000	1067811	38	M12x1.75x50	17.2	75.4	24.6	50.8	54.1	23.6	27.2	45.5	5/8, 3/4	3-1/4, 4-3/4	2, 1.5	3-1/4, 4-1/2
.68	1400	1067815	81	M16x2.0x60	27.2	75.4	24.6	50.8	54.1	23.6	27.2	45.5	5/8, 3/4	3-1/4, 4-3/4	2, 1.5	3-1/4, 4-1/2
2.0	2250	1067823	136	M20x2.5x75	28.1	110	34.0	76.2	76.2	27.2	34.4	61.5	7/8	6-1/2	2	6-1/4
2.2	3500	1067827	312	M24x3.0x80	33.1	110	34.0	76.2	76.2	27.2	34.4	61.5	7/8	6-1/2	2	6-1/4
4.5	6250	1067831	637	M30x3.5x120	65.1	142	39.9	95.3	99.3	37.3	48.8	86.9	1, 1-1/8, 1-1/4	8-1/2, 9-1/2, 12	3	8-1/2
10.4	7750	1067835	1006	M36x4.0x150	60.6	186	52.3	121	132	53.6	61.2	109	1-3/8, 1-1/2, 1-3/4	13-1/2, 17, 25	-	-
10.7	10000	1067839	1006	M42x4.5x160	70.6	186	52.3	121	132	53.6	61.2	109	1-3/8, 1-1/2, 1-3/4	13-1/2, 17, 25	-	-
11.0	13000	1067843	1350	M48x5.0x160	70.6	186	52.3	121	132	53.6	61.2	109	1-3/8, 1-1/2, 1-3/4	13-1/2, 17, 25	-	-

* Ultimate Load is 5 times the Working Load Limit.

Hoist Ring to Chain or Webbing



SEE APPLICATION AND WARNING INFORMATION

On Pages 156-157

HR-125C



- Available in capacities from 2 to 8.2 tonnes.
- Fits Grade 8 Chain size 7, 8, 10, 13 and 16mm.
- Full 360 degrees swivel and 180 degrees pivot action.
- "Yellow Chromate" finish for increased corrosion protection.
- Design factor of 4 to 1.
- Individually Proof Tested to 2-1/2 times Working Load Limit.
- Forged Alloy Steel.
- Bolt specification is a Grade 8 Alloy socket head cap screw to ASTM A574. All threads are UNC.

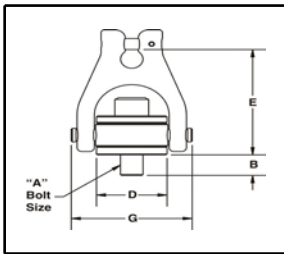

HR-125C Hoist Ring to Chain

HR-125C Stock No.	Working Load Limit (t)	Torque in Ft.-Lbs.	Effective Thread Projection Length (mm)	Spectrum 8 Chain Size (in. - mm)	Dimension (mm)					Weight Each (kg)
					UNC Thread A	B	D	E	G	
1067492	2	60	18.0	1/4-5/16 7-8	5/8-11 x 2.00	17.8	49.8	90.0	85.0	.95
1067494	2††	60	37.1	1/4-5/16 7-8	5/8-11 x 2.00	30.5	49.8	90.0	85.0	.95
1067500	3.2	100	22.9	3/8 10	3/4-10 x 2.75	22.6	75.0	121	124	2.45
1067502	3.2††	100	41.9	3/8 10	3/4-10 x 3.50	41.7	75.0	121	124	2.45
1067509	5.4	230	29.2	1/2 13	1-8 x 3.00	29.0	75.0	122	124	2.90
1067511	5.4††	230	54.6	1/2 13	1-8 x 4.00	54.5	75.0	122	124	3.04
1067518	8.2	470	56.4	5/8 16	1-1/4-7 x 4.50	56.0	94.0	166	157	5.81

* Ultimate load is 4 times the Working Load Limit. Individually tested to 2-1/2 the Working Load Limit

†† Long Bolts are designed to be used with soft metal (i.e., aluminum) work piece. While the long bolts may also be used with ferrous metal (i.e., steel & iron).

HR-125W



- Available in capacities from 2.95 to 5.67t.
- Fits webbing sizes 50 to 100mm.
- Design Factor of 5 to 1.
- Forged Alloy Steel
- Durable plastic cover protects the sling at the eye as well as keeps the sling positioned correctly on the spool.
- Designed for use with Type III (Eye & Eye), class 7, 2 ply webbing & synthetic round slings. Also accommodates single ply endless slings.
- Bolt specification is a Grade 8 Alloy socket head cap screw to ASTM A574. All threads are UNC.

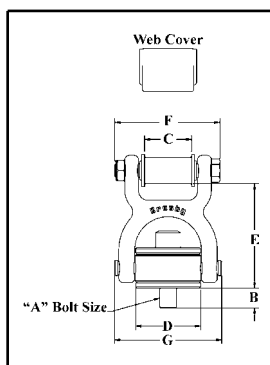

HR-125W Hoist Ring to Web

HR-125W Stock No.	Round Sling Size (No.)	Web Width (mm)	Eye Width (mm)	Working Load Limit (t)	Torque in Ft.-lbs.	Eff. Thread Proj. Length (mm)	Spool bolt & nut Torque in Ft.-Lbs.	Dimension (mm)							Weight Each (kg)
								A	B	C	D	E	F	G	
1067610	1 & 2	50	50	2.95	100	22.9	90	3/4-10x2.75	22.6	54.0	75.0	121	121	124	2.81
1067615	1 & 2	50	50	2.95	100	41.9	90	3/4-10x3.50	41.7	54.0	75.0	121	121	124	2.86
1067629	3	75	35	4.08	230	29.2	110	1-8x3.00	29.0	41.4	75.0	121	115	124	3.22
1067634	3	75	35	4.08	230	54.6	110	1-8x4.00	54.5	41.4	75.0	121	115	124	3.31
1067638	4	100	50	5.67	470	56.4	130	1-1/4-7x4.5	56.0	54.0	94.0	158	109	157	6.21

* Ultimate load is 5 times the Working Load Limit. Individually tested to 2-1/2 times the Working Load Limit.

†† Long Bolts are designed to be used with soft metal (i.e., aluminum) work piece. While the long bolts may also be used with ferrous metal (i.e., steel & iron).

Crosby® Turnbuckles



HG-223
Hook & Hook

Meets the performance requirements of Federal Specifications FF-T791b, Type 1, Form 1 — Class 5, and ASTM F-1145, except for those provisions required of the contractor.



HG-225
Hook & Eye

Meets the performance requirements of Federal Specifications FF-T791b, Type 1, Form 1 — Class 6, and ASTM F-1145, except for those provisions required of the contractor.



HG-226
Eye & Eye

Meets the performance requirements of Federal Specifications FF-T791b, Type 1, Form 1 — Class 4, and ASTM F-1145, except for those provisions required of the contractor.



HG-227
Jaw & Eye

Meets the performance requirements of Federal Specifications FF-T791b, Type 1, Form 1 — Class 8, and ASTM F-1145, except for those provisions required of the contractor.



HG-228
Jaw & Jaw

Meets the performance requirements of Federal Specifications FF-T791b, Type 1, Form 1 — Class 7, and ASTM F-1145, except for those provisions required of the contractor.

- Hot Dip galvanized.
- End fittings are Quenched and Tempered, bodies heat treated by normalizing.
- Hooks are forged with a greater cross sectional area that results in a stronger hook with better fatigue properties.
- Modified UNJ thread on end fittings for improved fatigue properties. Body has UNC threads.
- Turnbuckle eyes are forged elongated, by design, to maximize easy attachment in system and minimize stress in the eye. For turnbuckle sizes 1/4" through 2-1/2", a shackle one size smaller can be reeved through eye.
- Forged jaw ends are fitted with bolts and nuts on sizes 1/4" through 5/8", and pins and cotters on sizes 3/4" through 2-3/4".
- TURNBUCKLES RECOMMENDED FOR STRAIGHT OR IN-LINE PULL ONLY.
- Lock Nuts available for all sizes.
- Crosby's Quenched and Tempered end fittings and normalized bodies have enhanced impact properties for greater toughness at all temperatures.
- Typical hardness levels, Tensile Strengths and Ductility Properties are available for all sizes.
- Turnbuckles can be furnished proof tested or magnaflux inspected with certificates if requested at time of order.
- Turnbuckle assembly combinations include: Eye and Eye, Hook and Hook, Hook and Eye, Jaw and Jaw, Jaw and Eye.



Modified thread:
Note stress relieving radii in this unretouched photo enlargement of the supabuckle.

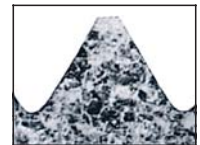

Standard thread:
Note stress building sharp "V" in this unretouched photo enlargement.

Hook & Hook Turnbuckles



Fatigue Rated

HG-223



- Hot Dip galvanized steel.
- End fittings are Quenched and Tempered, bodies heat treated by normalizing.
- Hooks are forged with a greater cross sectional area that results in a stronger hook with better fatigue properties.
- TURNBUCKLES RECOMMENDED FOR STRAIGHT OR IN-LINE PULLS ONLY.
- Modified UNJ thread on end fittings for improved fatigue properties.
- Body has UNC threads.
- Lock Nuts available for all sizes (see page 153).
- Comprehensive end fitting data provided on page 149.
- Fatigue Rated.

Meets the performance requirements of Federal Specifications FF-T-791b, Type 1 Form 1 - CLASS 5, except for those provisions required of the contractor.

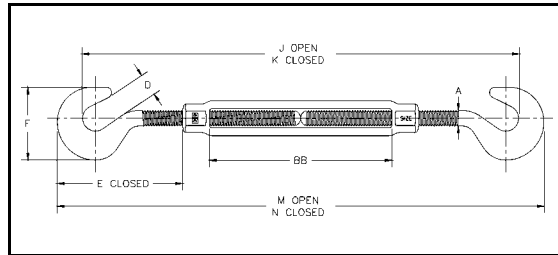

HG-223 Hook & Hook

Thread Diameter & Take Up (in.)	Thread Diameter & Take Up (mm)	HG-223 Stock No.	Working Load Limit (t) [*]	Weight Each (kg)	Dimensions (mm)								
					A	D	E Closed	F	J Open	K Closed	M Open	N Closed	BB
1/4 x 4	6.35 x 102	1030011	.18	.14	6.35	11.4	40.4	32.3	282	181	303	202	101
5/16 x 4-1/2	7.94 x 114	1030039	.32	.21	7.85	12.7	49.3	38.1	325	211	351	236	114
3/8 x 6	9.53 x 152	1030057	.45	.35	9.65	14.2	58.5	45.0	419	267	450	298	152
1/2 x 6	12.7 x 152	1030075	.68	.73	12.7	16.8	74.5	58.0	478	300	518	340	152
1/2 x 12	12.7 x 305	1030119	.68	1.03	12.7	16.8	74.5	58.0	783	453	822	492	304
5/8 x 6	15.9 x 305	1030137	1.02	1.25	16.0	22.9	93.5	71.5	521	337	572	387	152
5/8 x 12	15.9 x 305	1030173	1.02	1.59	16.0	22.9	93.5	71.5	826	489	876	540	304
3/4 x 6	19.1 x 152	1030191	1.36	1.76	19.1	24.9	115	84.5	568	378	629	439	152
3/4 x 12	19.1 x 305	1030235	1.36	2.46	19.1	24.9	115	84.5	873	530	934	591	304
3/4 x 18	19.1 x 457	1030253	1.36	3.68	19.1	24.9	115	84.5	1178	683	1239	744	457
7/8 x 12	22.2 x 305	1030271	1.81	3.67	22.2	28.7	132	96.0	914	565	984	635	304
1 x 12	25.4 x 305	1030333	2.27	5.41	25.4	31.8	148	108	956	600	1034	678	304
1 x 18	25.4 x 457	1030351	2.27	6.35	25.4	31.8	148	108	1261	753	1338	830	457
1 x 24	25.4 x 610	1030379	2.27	7.82	25.4	31.8	148	108	1565	905	1643	983	609
1-1/4 x 12	31.8 x 305	1030397	2.95	9.33	31.8	38.1	183	130	1027	659	1119	751	304
1-1/4 x 18	31.8 x 457	1030413	2.95	10.4	31.8	38.1	183	130	1332	811	1424	903	457
1-1/4 x 24	31.8 x 610	1030431	2.95	12.2	31.8	38.1	183	130	1637	964	1729	1056	609
1-1/2 x 12	38.1 x 305	1030459	3.40	12.5	38.1	47.8	212	146	1116	735	1205	824	304
1-1/2 x 18	38.1 x 457	1030477	3.40	14.1	38.1	47.8	212	146	1421	887	1510	976	457
1-1/2 x 24	38.1 x 610	1030495	3.40	17.0	38.1	47.8	212	146	1726	1040	1815	1129	609

* Proof Load is 2.5 times the Working Load Limit. Ultimate Load is 5 times the Working Load Limit.

Hook & Eye Turnbuckles



Fatigue Rated

HG-225



- Hot Dip galvanized steel.
- End fittings are Quenched and Tempered, bodies heat treated by normalizing.
- Turnbuckle eyes are forged elongated, by design, to maximize easy attachment in system and minimize stress in the eye. For turnbuckles sizes 6 mm through 64 mm, a shackle one size smaller can be reeved through eye.
- Turnbuckle hooks are forged with a greater cross sectional area that results in a stronger hook with better fatigue properties.
- TURNBUCKLES RECOMMENDED FOR STRAIGHT OR IN-LINE PULL ONLY.
- Modified UNJ thread on end fittings for improved fatigue properties.
- Body has UNC threads.
- Lock Nuts available for all sizes (see page 153).
- Comprehensive end fitting data provided on pages 149 & 150.
- Fatigue Rated.

Meets the performance requirements of Federal Specifications FF-T-791b, Type 1, Form 1 — CLASS 6, except for those provisions required of the contractor.

Rigging Accessories

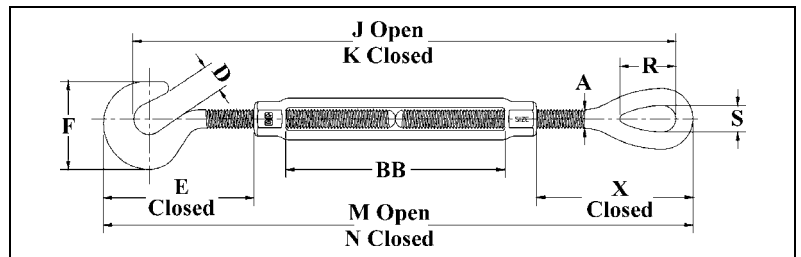

HG-225 Hook & Eye

Thread Diameter & Take Up (in.)	Thread Diameter & Take Up (mm)	HG-225 Stock No.	Working Load Limit (t)*	Weight Each (kg)	Dimensions (mm)												
					A	D	E Closed	F	J Open	K Closed	M Open	N Closed	R	S	X Closed	BB	
1/4 x 4	6.35 x 102	1030636	.18	.13	6.35	11.4	40.4	32.3	291	189	307	205	19.8	8.64	44.5	102	
5/16 x 4-1/2	7.94 x 114	1030654	.32	.22	7.94	12.7	49.3	38.1	335	221	342	241	23.9	11.2	53.0	114	
3/8 x 6	9.53 x 152	1030672	.45	.35	9.53	14.2	58.0	45.0	431	279	456	303	28.5	13.5	64.0	152	
1/2 x 6	12.7 x 152	1030690	.68	.73	12.7	16.8	74.5	58.0	494	316	525	347	36.6	18.3	82.0	152	
1/2 x 12	12.7 x 305	1030734	.68	1.03	12.7	16.8	74.5	58.0	798	469	829	500	36.6	18.3	82.0	305	
5/8 x 6	15.9 x 152	1030752	1.02	1.22	15.9	21.3	93.5	71.0	557	355	577	393	44.5	22.2	99.0	152	
5/8 x 12	15.9 x 305	1030798	1.02	1.71	15.9	21.3	93.5	71.0	844	507	882	545	44.5	22.2	99.0	305	
3/4 x 6	19.1 x 152	1030814	1.36	1.76	19.1	24.9	115	85.0	587	397	634	443	53.0	25.4	119	152	
3/4 x 12	19.1 x 305	1030850	1.36	2.64	19.1	24.9	115	84.5	892	549	939	596	53.0	25.4	119	305	
3/4 x 18	19.1 x 457	1030878	1.36	2.87	19.1	24.9	115	84.5	1197	702	1243	748	53.0	25.4	119	457	
7/8 x 12	22.2 x 305	1030896	1.81	3.67	22.2	28.7	132	96.0	927	579	982	633	60.0	31.8	130	305	
1 x 12	25.4 x 305	1030958	2.27	5.41	25.4	31.8	148	108	985	630	1046	691	76.0	36.6	162	305	
1 x 18	25.4 x 457	1030976	2.27	6.35	25.4	31.8	148	108	1290	782	1351	843	76.0	36.6	162	457	
1 x 24	25.4 x 610	1030994	2.27	7.82	25.4	31.8	148	108	1595	935	1656	996	76.0	36.6	162	610	
1-1/4 x 12	31.8 x 305	1031010	2.95	8.62	31.8	38.1	183	130	1057	689	1132	764	90.0	46.0	196	305	
1-1/4 x 18	31.8 x 457	1031038	2.95	10.4	31.8	38.1	183	130	1362	842	1437	916	90.0	46.0	196	457	
1-1/4 x 24	31.8 x 610	1031056	2.95	10.9	31.8	38.1	183	130	1667	994	1741	1068	90.0	46.0	196	610	
1-1/2 x 12	38.1 x 305	1031074	3.40	12.5	38.1	47.8	212	146	1136	755	1212	831	103	54.0	219	305	
1-1/2 x 18	38.1 x 457	1031092	3.40	14.1	38.1	47.8	212	146	1441	907	1517	983	103	54.0	219	457	
1-1/2 x 24	38.1 x 610	1031118	3.40	17.0	38.1	47.8	212	146	1745	1060	1822	1136	103	54.0	219	610	

* Proof Load is 2.5 times the Working Load Limit. Ultimate Load is 5 times the Working Load Limit.

Eye & Eye Turnbuckles



Fatigue Rated

HG-226



- Hot Dip galvanized steel.
- End fittings are Quenched and Tempered, bodies heat treated by normalizing.
- Turnbuckle eyes are forged elongated, by design, to maximize easy attachment in system and minimize stress in the eye. For turnbuckle sizes 1/4" through 2-1/2", a shackle one size smaller can be reeved through eye.
- Modified UNJ thread on end fittings for improved fatigue properties. Body has UNC threads.
- TURNBUCKLES RECOMMENDED FOR STRAIGHT OR IN-LINE PULL ONLY.
- Lock Nuts available for all sizes (see page 153).
- Comprehensive end fitting data provided on page 150.
- Fatigue Rated.

Meets the performance requirements of Federal Specifications FF-T-791b, Type 1, Form 1 - CLASS 4, except for those provisions required of the contractor.

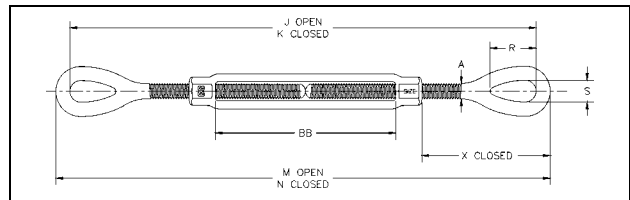

HG-226 Eye & Eye

Thread Diameter & Take Up (in.)	Thread Diameter & Take Up (mm)	HG-226 Stock No.	Working Load Limit (t)*	Weight Each (kg)	Dimensions (mm)								
					A	J Open	K Closed	M Open	N Closed	R	S	X Closed	BB
1/4 x 4	6.35 x 102	1031252	.23	.12	6.35	300	198	311	210	19.8	8.65	44.5	101
5/16 x 4-1/2	7.94 x 114	1031270	.36	.20	7.85	344	230	359	244	23.8	11.1	53.0	114
3/8 x 6	9.53 x 152	1031298	.54	.34	9.65	444	291	461	309	28.4	13.4	64.0	152
1/2 x 6	12.7 x 152	1031314	1.00	.70	12.7	510	332	532	355	36.5	18.2	82.0	152
1/2 x 12	12.7 x 305	1031350	1.00	.97	12.7	815	485	837	507	36.5	18.2	82.0	304
5/8 x 6	15.9 x 152	1031378	1.59	1.49	16.0	557	373	582	398	44.4	22.3	99.0	152
5/8 x 12	15.9 x 305	1031412	1.59	1.55	16.0	862	525	887	551	44.4	22.3	99.0	304
3/4 x 6	19.1 x 152	1031430	2.36	1.72	19.1	607	416	638	448	53.0	25.4	119	152
3/4 x 12	19.1 x 305	1031476	2.36	2.49	19.1	911	568	943	600	53.0	25.4	119	304
3/4 x 18	19.1 x 457	1031494	2.36	3.26	19.1	1216	721	1248	752	53.0	25.4	119	457
7/8 x 12	22.2 x 305	1031519	3.27	3.27	22.4	942	592	980	630	60.4	31.7	130	304
7/8 x 18	22.2 x 457	1031537	3.27	4.51	22.4	1246	745	1284	783	60.4	31.7	130	457
1 x 6	25.4 x 152	1031555	4.54	4.10	25.4	710	507	755	552	76.0	36.5	162	152
1 x 12	25.4 x 305	1031573	4.54	5.22	25.4	1015	660	1066	704	76.0	36.5	162	304
1 x 18	25.4 x 457	1031591	4.54	6.35	25.4	1320	812	1364	856	76.0	36.5	162	457
1 x 24	25.4 x 610	1031617	4.54	7.82	25.4	1625	964	1669	1009	76.0	36.5	162	609
1-1/4 x 12	31.8 x 305	1031635	6.89	8.62	31.8	1087	719	1145	776	90.5	46.0	196	304
1-1/4 x 18	31.8 x 457	1031653	6.89	10.4	31.8	1392	871	1449	929	90.5	46.0	196	457
1-1/4 x 24	31.8 x 610	1031671	6.89	12.2	31.8	1697	1024	1754	1081	90.5	46.0	196	609
1-1/2 x 12	38.1 x 305	1031699	9.71	12.5	38.1	1156	775	1219	838	103	54.0	219	304
1-1/2 x 18	38.1 x 457	1031715	9.71	14.1	38.1	1461	927	1524	991	103	54.0	219	457
1-1/2 x 24	38.1 x 610	1031733	9.71	17.0	38.1	1765	1080	1829	1143	103	54.0	219	609
1-3/4 x 18	44.5 x 457	1031779	12.7	23.8	44.5	1457	1000	1534	1076	117	60.4	254	457
1-3/4 x 24	44.5 x 610	1031797	12.7	26.3	44.5	1762	1153	1838	1229	117	60.4	254	609
2 x 24	51.0 x 610	1031813	16.8	38.7	51.0	1923	1313	2011	1402	146	68.5	333	609
2-1/2 x 24	63.5 x 610	1031831	27.2	65	63.5	1997	1387	2099	1489	165	79.0	350	609
2-3/4 x 24	70.0 x 610	1031859	34.0	88	70.0	2057	1448	2172	1562	177	82.5	387	609

* Proof Load is 2.5 times the Working Load Limit. Ultimate Load is 5 times the Working Load Limit.

Jaw & Eye Turnbuckles



Fatigue Rated

HG-227



- Hot Dip galvanized steel.
- End fittings are Quenched and Tempered, bodies heat treated by normalizing.
- Turnbuckles eyes are forged and elongated, by design, to maximize easy attachment in system and minimize stress in the eye. For turnbuckles size 6 mm through 64 mm, a shackle one size smaller can be reeved through eye.
- Forged jaw ends are fitted with bolts and nuts for 6 mm through 16 mm, and pins and cotters on 19 mm through 70 mm sizes.
- Modified UNJ thread on end fittings for improved fatigue properties.
- Body has UNC threads.
- TURNBUCKLES RECOMMENDED FOR STRAIGHT OR IN-LINE PULL ONLY.
- Lock Nuts available for all sizes (see page 153).
- Comprehensive End fitting data on pages 150 & 151.
- Fatigue Rated.

Meets the performance requirements of Federal Specifications FF-T-791b, Type 1, Form 1 - CLASS 8, except for those provisions required of the contractor.

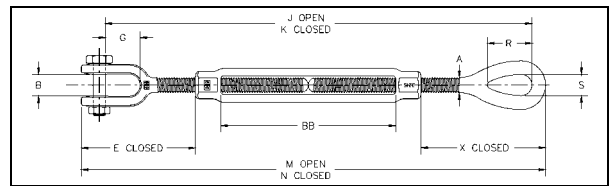

HG-227 Jaw & Eye

Thread Diameter & Take Up (in.)	Thread Diameter & Take Up (mm)	HG-227 Stock No.	Working Load Limit (t)*	Weight Each (kg)	Dimensions (mm)												
					A	B	E Closed	G	J Open	K Closed	M Open	N Closed	R	S	X Closed	BB	
1/4 x 4	6.35 x 102	1031877	.23	.14	6.35	11.4	40.1	15.7	288	187	307	205	19.8	8.65	44.5	101	
5/16 x 4-1/2	7.94 x 114	1031895	.36	.23	7.85	12.7	50.5	22.1	348	221	356	242	23.8	11.1	53.0	114	
3/8 x 6	9.53 x 152	1031911	.54	.36	9.65	13.7	54.0	22.1	427	275	451	299	28.4	13.4	64.0	152	
1/2 x 6	12.7 x 152	1031939	1.00	.68	12.7	16.5	70.0	26.9	490	312	520	342	36.5	18.2	82.0	152	
1/2 x 9	12.7 x 229	1031957	1.00	.78	12.7	16.5	70.0	26.9	642	388	673	419	36.5	18.2	82.0	228	
1/2 x 12	12.7 x 305	1031975	1.00	.94	12.7	16.5	70.0	26.9	795	465	825	495	36.5	18.2	82.0	304	
5/8 x 6	15.9 x 305	1031993	1.59	1.07	16.0	20.1	89.0	33.3	533	349	572	388	44.4	22.3	99.0	152	
5/8 x 9	15.9 x 229	1032019	1.59	1.44	16.0	20.1	89.0	33.3	686	425	725	464	44.4	22.3	99.0	228	
5/8 x 12	15.9 x 305	1032037	1.59	1.64	16.0	20.1	89.0	33.3	838	501	877	541	44.4	22.3	99.0	304	
3/4 x 6	19.1 x 152	1032055	2.36	1.81	19.1	23.9	106	38.1	576	386	625	435	53.0	25.4	119	152	
3/4 x 9	19.1 x 229	1032073	2.36	2.15	19.1	23.9	106	38.1	729	462	777	511	53.0	25.4	119	228	
3/4 x 12	19.1 x 305	1032091	2.36	2.69	19.1	23.9	106	38.1	881	538	930	587	53.0	25.4	119	304	
3/4 x 18	19.1 x 457	1032117	2.36	3.18	19.1	23.9	106	38.1	1186	691	1235	739	53.0	25.4	119	457	
7/8 x 12	22.2 x 305	1032135	3.27	3.79	22.4	28.7	123	44.5	917	567	973	624	60.4	31.7	130	304	
7/8 x 18	22.2 x 457	1032153	3.27	4.42	22.4	28.7	123	44.5	1221	720	1278	776	60.4	31.7	130	457	
1 x 6	25.4 x 152	1032171	4.54	4.05	25.4	34.0	140	52.5	669	466	734	531	76.0	36.5	162	152	
1 x 12	25.4 x 305	1032199	4.54	5.08	25.4	34.0	140	52.5	974	618	1039	683	76.0	36.5	162	304	
1 x 18	25.4 x 457	1032215	4.54	6.03	25.4	34.0	140	52.5	1279	771	1343	835	76.0	36.5	162	457	
1 x 24	25.4 x 610	1032233	4.54	7.71	25.4	34.0	140	52.5	1583	923	1648	988	76.0	36.5	162	609	
1-1/4 x 12	31.8 x 305	1032251	6.89	8.81	31.8	44.5	183	71.5	1050	681	1132	763	90.5	46.0	196	304	
1-1/4 x 18	31.8 x 457	1032279	6.89	11.0	31.8	44.5	183	71.5	1354	834	1424	916	90.5	46.0	196	457	
1-1/4 x 24	31.8 x 610	1032297	6.89	12.9	31.8	44.5	183	71.5	1659	986	1741	1068	90.5	46.0	196	609	
1-1/2 x 12	38.1 x 305	1032313	9.71	13.1	38.1	52.3	200	71.5	1105	724	1200	819	103	54.0	219	304	
1-1/2 x 18	38.1 x 457	1032331	9.71	15.9	38.1	52.3	200	71.5	1410	876	1505	972	103	54.0	219	457	
1-1/2 x 24	38.1 x 610	1032359	9.71	17.8	38.1	52.3	200	71.5	1715	1029	1810	1124	103	54.0	219	609	
1-3/4 x 18	44.5 x 457	1032395	12.7	24.4	44.5	66.0	239	86.0	1407	949	1518	1061	117	60.4	254	457	
1-3/4 x 24	44.5 x 610	1032411	12.7	27.5	44.5	66.0	239	86.0	1711	1102	1823	1214	117	60.4	254	609	
2 x 24	51.0 x 610	1032439	16.8	40.4	51.0	66.5	301	93.5	1845	1235	1980	1370	146	68.3	332	609	
2-1/2 x 24	63.5 x 610	1032457	27.2	68	63.5	76.5	344	113	1925	1316	2093	1483	165	79.0	350	609	
2-3/4 x 24	70.0 x 610	1032475	34.0	83	70.0	92.2	387	106	1978	1369	2172	1562	177	82.5	387	609	

* Proof Load is 2.5 times the Working Load Limit. Ultimate Load is 5 times the Working Load Limit.

Jaw & Jaw Turnbuckles



Fatigue Rated

HG-228



- Hot Dip galvanized steel.
- End fittings are Quenched and Tempered, bodies heat treated by normalizing.
- TURNBUCKLES RECOMMENDED FOR STRAIGHT OR IN-LINE PULL ONLY.
- Forged jaw ends are fitted with bolts and nuts for 6 mm through 64 mm, and pins and cotters on 19 mm through 70 mm sizes.
- Modified UNJ thread on end fittings for improved fatigue properties.
- Body has UNC threads.
- Lock Nuts available for all sizes (see page 153).
- Comprehensive end fitting data provided on page 151.
- Fatigue Rated.

Meets the performance requirements of Federal Specifications FF-T-791b, Type 1, Form 1 - CLASS 7, except for those provisions required of the contractor.

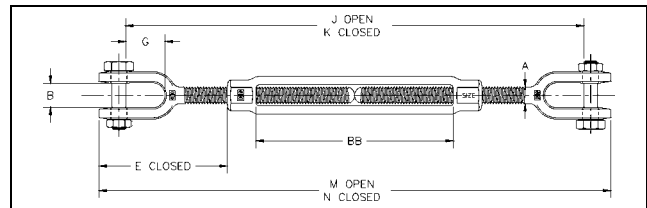

HG-228 Jaw & Jaw

Thread Diameter & Take Up (in.)	Thread Diameter & Take Up (mm)	HG-228 Stock No.	Working Load Limit (t)*	Weight Each (kg)	Dimensions (mm)									
					A	B	E Closed	G	J Open	K Closed	M Open	N Closed	BB	
1/4 x 4	6.35 x 102	1032493	.23	.16	6.35	11.4	40.1	15.7	277	175	302	201	102	
5/16 x 4-1/2	7.94 x 114	1032518	.36	.24	7.85	12.7	50.5	22.1	314	212	353	239	114	
3/8 x 6	9.53 x 152	1032536	.54	.37	9.65	13.7	54.0	22.1	410	258	441	289	152	
1/2 x 6	12.7 x 152	1032554	1.00	.71	12.7	16.5	70.0	26.9	470	292	508	330	152	
1/2 x 9	12.7 x 229	1032572	1.00	.79	12.7	16.5	70.0	26.9	622	368	660	406	229	
1/2 x 12	12.7 x 305	1032590	1.00	1.09	12.7	16.5	70.0	26.9	775	445	813	483	305	
5/8 x 6	15.9 x 305	1032616	1.59	1.23	16.0	20.1	89.0	33.3	509	325	562	378	152	
5/8 x 9	15.9 x 229	1032634	1.59	1.56	16.0	20.1	89.0	33.3	662	401	715	454	229	
5/8 x 12	15.9 x 305	1032652	1.59	1.77	16.0	20.1	89.0	33.3	814	478	867	530	305	
3/4 x 6	19.1 x 152	1032670	2.36	1.86	19.1	23.9	106	38.1	546	356	612	422	152	
3/4 x 9	19.1 x 229	1032698	2.36	2.48	19.1	23.9	106	38.1	699	432	765	498	229	
3/4 x 12	19.1 x 305	1032714	2.36	2.98	19.1	23.9	106	38.1	851	508	917	574	305	
3/4 x 18	19.1 x 457	1032732	2.36	3.64	19.1	23.9	106	38.1	1156	660	1222	726	457	
7/8 x 12	22.2 x 305	1032750	3.27	3.71	22.4	28.7	123	44.5	892	543	967	618	305	
7/8 x 18	22.2 x 457	1032778	3.27	4.89	22.4	28.7	123	44.5	1197	695	1272	770	457	
1 x 6	25.4 x 152	1032796	4.54	4.62	25.4	34.0	140	52.5	628	425	713	510	152	
1 x 12	25.4 x 305	1032812	4.54	5.53	25.4	34.0	140	52.5	933	577	1018	662	305	
1 x 18	25.4 x 457	1032830	4.54	6.87	25.4	34.0	140	52.5	1237	729	1322	814	457	
1 x 24	25.4 x 610	1032858	4.54	8.20	25.4	34.0	140	52.5	1542	882	1627	967	610	
1-1/4 x 12	31.8 x 305	1032876	6.89	9.34	31.8	44.5	183	71.5	1012	644	1119	750	305	
1-1/4 x 18	31.8 x 457	1032894	6.89	11.2	31.8	44.5	183	71.5	1317	796	1423	903	457	
1-1/4 x 24	31.8 x 610	1032910	6.89	12.8	31.8	44.5	183	71.5	1622	948	1728	1055	610	
1-1/2 x 12	38.1 x 305	1032938	9.71	13.9	38.1	52.3	200	71.5	1054	673	1181	800	305	
1-1/2 x 18	38.1 x 457	1032956	9.71	16.7	38.1	52.3	200	71.5	1359	826	1486	953	457	
1-1/2 x 24	38.1 x 610	1032974	9.71	18.9	38.1	52.3	200	71.5	1664	978	1791	1105	610	
1-3/4 x 18	44.5 x 457	1033018	12.7	24.5	44.5	66.0	239	86.0	1356	899	1503	1046	457	
1-3/4 x 24	44.5 x 610	1033036	12.7	28.7	44.5	66.0	239	86.0	1661	1051	1808	1198	610	
2 x 24	51.0 x 610	1033054	16.8	42.8	51.0	66.5	301	93.5	1766	1157	1949	1339	610	
2-1/2 x 24	63.5 x 610	1033072	27.2	75	63.5	76.5	344	113	1854	1244	2087	1478	610	
2-3/4 x 24	70.0 x 610	1033090	34.0	90	70.0	92.2	387	106	1899	1289	2172	1562	610	

* Proof Load is 2.5 times the Working Load Limit. Ultimate Load is 5 times the Working Load Limit.

Turnbuckle - Hook End Fittings



Fatigue Rated

HOOK END FITTINGS

- Hot Dip galvanized steel.
- Quenched and Tempered.
- Hooks are forged with a greater cross sectional area that results in a stronger hook with better fatigue properties.
- Modified UNJ thread for improved fatigue properties.
- Fatigue Rated.

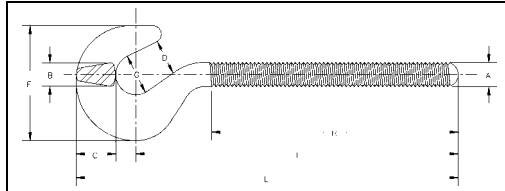

**HG-4037
Hook End Fittings**

Shank Diameter & Take Up (in.)	Shank Diameter & Take Up (mm)	RH Hook Stock No.	LH Hook Stock No.	Working Load Limit (t)	Weight Each (kg)	Dimensions (mm)									
						A	B	C	D	F	G	H	I	L	
1/4 x 4	6.35 x 102	1070012	1070539	.18	.04	6.35	6.35	10.4	11.4	32.3	12.7	65.0	84.0	101	
5/16 x 4-1/2	7.94 x 114	1070030	1070557	.32	.07	7.85	7.85	12.7	12.7	38.1	14.2	76.5	97.0	118	
3/8 x 6	9.53 x 152	1070058	1070575	.45	.11	9.65	9.65	15.5	14.2	45.0	15.7	97.0	125	149	
1/2 x 6	12.7 x 152	1070076	1070593	.68	.24	12.7	12.7	19.8	16.8	58.0	20.6	108	140	170	
1/2 x 9	12.7 x 229	1070094	1070619	.68	.27	12.7	12.7	19.8	16.8	58.0	20.6	146	178	208	
1/2 x 12	12.7 x 305	1070110	1070637	.68	.31	12.7	12.7	19.8	16.8	58.0	20.6	184	216	246	
5/8 x 6	15.9 x 305	1070138	1070655	1.02	.41	16.0	16.0	25.4	22.9	71.5	25.4	116	156	194	
5/8 x 9	15.9 x 229	1070156	1070673	1.02	.47	16.0	16.0	25.4	22.9	71.5	25.4	154	194	232	
5/8 x 12	15.9 x 305	1070174	1070691	1.02	.53	16.0	16.0	25.4	21.3	71.5	25.4	192	232	270	
3/4 x 6	19.1 x 152	1070192	1070717	1.36	.70	19.1	19.1	30.5	24.9	84.5	28.7	116	175	219	
3/4 x 9	19.1 x 229	1070218	1070735	1.36	.78	19.1	19.1	30.5	24.9	84.5	28.7	154	213	258	
3/4 x 12	19.1 x 305	1070236	1070753	1.36	1.00	19.1	19.1	30.5	24.9	84.5	28.7	192	251	296	
3/4 x 18	19.1 x 457	1070254	1070771	1.36	1.13	19.1	19.1	30.5	24.9	84.5	28.7	268	327	372	
7/8 x 12	22.2 x 305	1070272	1070799	1.81	1.13	22.4	22.4	35.1	28.7	96.0	31.8	198	267	318	
7/8 x 18	22.2 x 457	1070290	1070815	1.81	1.36	22.4	22.4	35.1	28.7	96.0	31.8	274	343	394	
1 x 6	25.4 x 152	1070316	1070833	2.27	1.56	25.4	25.4	38.9	31.8	108	35.1	128	207	263	
1 x 12	25.4 x 305	1070334	1070851	2.27	1.91	25.4	25.4	38.9	31.8	108	35.1	204	282	339	
1 x 18	25.4 x 457	1070352	1070879	2.27	2.13	25.4	25.4	38.9	31.8	108	35.1	281	359	415	
1 x 24	25.4 x 610	1070370	1070897	2.27	2.36	25.4	25.4	38.9	31.8	108	35.1	357	435	491	
1-1/4 x 12	31.8 x 305	1070398	1070913	2.95	2.95	31.8	31.8	46.0	38.1	130	44.5	210	307	375	
1-1/4 x 18	31.8 x 457	1070414	1070931	2.95	3.10	31.8	31.8	46.0	38.1	130	44.5	287	383	452	
1-1/4 x 24	31.8 x 610	1070432	1070959	2.95	4.08	31.8	31.8	46.0	38.1	130	44.5	363	459	528	
1-1/2 x 12	38.1 x 305	1070450	1070977	3.40	3.97	38.1	33.3	44.5	47.8	146	57.0	221	339	412	
1-1/2 x 18	38.1 x 457	1070478	1070995	3.40	4.51	38.1	33.3	44.5	47.8	146	57.0	298	415	488	
1-1/2 x 24	38.1 x 610	1070496	1071011	3.40	5.08	38.1	33.3	44.5	47.8	146	57.0	374	491	564	

Turnbuckle - Eye End Fittings



Fatigue Rated

EYE END FITTINGS

- Hot Dip galvanized steel.
- Quenched and Tempered.
- Turnbuckle eyes are forged elongated, by design, to maximize easy attachment in system and minimize stress in the eye. For turnbuckle sizes 6 mm through 64 mm, a shackle one size smaller can be reeved through eye.
- Modified UNJ thread for improved fatigue properties.
- Fatigue Rated.

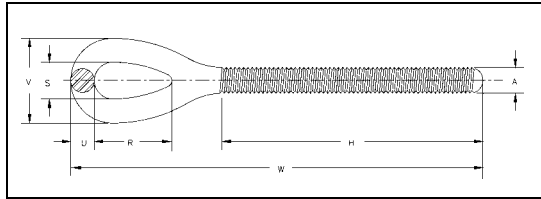

HG-4037 Eye End Fittings

Shank Diameter & Take Up (in.)	Shank Diameter & Take Up (mm)	RH Eye Stock No.	LH Eye Stock No.	Working Load Limit (t)	Weight Each (kg)	Dimensions (mm)						
						A	H	R	S	U	V	W
1/4 x 4	6.35 x 102	1071057	1071672	.23	.03	6.35	65.0	19.8	8.65	5.60	19.8	104
5/16 x 4-1/2	7.94 x 114	1071075	1071690	.36	.06	7.85	74.0	23.8	11.1	7.10	25.4	122
3/8 x 6	9.53 x 152	1071093	1071716	.54	.11	9.65	96.5	28.4	13.4	8.65	31.0	154
1/2 x 6	12.7 x 152	1071119	1071734	1.00	.21	12.7	103	36.5	18.2	11.2	40.4	189
1/2 x 9	12.7 x 229	1071137	1071752	1.00	.25	12.7	141	36.5	18.2	11.2	40.4	228
1/2 x 12	12.7 x 305	1071155	1071770	1.00	.29	12.7	179	36.5	18.2	11.2	40.4	266
5/8 x 6	15.9 x 305	1071173	1071798	1.59	.38	16.0	109	44.4	22.3	12.7	47.8	215
5/8 x 9	15.9 x 229	1071191	1071814	1.59	.44	16.0	147	44.4	22.3	12.7	47.8	253
5/8 x 12	15.9 x 305	1071217	1071832	1.59	.47	16.0	185	44.4	22.3	12.7	47.8	291
3/4 x 6	19.1 x 152	1071235	1071850	2.36	.56	19.1	116	53.0	25.4	15.8	57.0	242
3/4 x 9	19.1 x 229	1071253	1071878	2.36	.64	19.1	154	53.0	25.4	15.8	57.0	280
3/4 x 12	19.1 x 305	1071271	1071896	2.36	.73	19.1	192	53.0	25.4	15.8	57.0	319
3/4 x 18	19.1 x 457	1071299	1071912	2.36	.90	19.1	268	53.0	25.4	15.8	57.0	395
7/8 x 12	22.2 x 305	1071315	1071930	3.27	1.16	22.4	198	60.4	31.7	19.1	70.0	337
7/8 x 18	22.2 x 457	1071333	1071958	3.27	1.39	22.4	274	60.4	31.7	19.1	70.0	413
1 x 6	25.4 x 152	1071351	1071976	4.54	1.40	25.4	128	76.0	36.5	22.4	81.0	301
1 x 12	25.4 x 305	1071379	1071994	4.54	1.70	25.4	204	76.0	36.5	22.4	81.0	377
1 x 18	25.4 x 457	1071397	1072010	4.54	2.01	25.4	281	76.0	36.5	22.4	81.0	453
1 x 24	25.4 x 610	1071413	1072038	4.54	2.10	25.4	357	76.0	36.5	22.4	81.0	529
1-1/4 x 12	31.8 x 305	1071431	1072056	6.89	2.95	31.8	210	90.5	46.0	28.5	103	419
1-1/4 x 18	31.8 x 457	1071459	1072074	6.89	3.31	31.8	287	90.5	46.0	28.5	103	496
1-1/4 x 24	31.8 x 610	1071477	1072092	6.89	3.76	31.8	363	90.5	46.0	28.5	103	572
1-1/2 x 12	38.1 x 305	1071495	1072118	9.71	3.49	38.1	221	103	54.0	31.8	117	457
1-1/2 x 18	38.1 x 457	1071510	1072136	9.71	5.90	38.1	298	103	54.0	31.8	117	533
1-1/2 x 24	38.1 x 610	1071538	1072154	9.71	5.28	38.1	374	103	54.0	31.8	117	609
1-3/4 x 18	44.5 x 457	1071574	1072190	12.7	7.82	44.5	309	117	60.4	38.1	137	538
1-3/4 x 24	44.5 x 610	1071592	1072216	12.7	8.34	44.5	385	117	60.4	38.1	137	614
2 x 24	51.0 x 610	1071618	1072234	16.8	14.1	51.0	396	146	68.3	44.5	157	700
2-1/2 x 24	63.5 x 610	1071636	1072252	27.2	19.4	63.5	437	165	79.2	51.0	181	744
2-3/4 x 24	70.0 x 610	1071654	1072270	34.0	31.7	70.0	440	177	82.5	57.0	197	781

Turnbuckle - Jaw End Fittings



Fatigue Rated

JAW END FITTINGS

- Hot dip galvanized steel.
- Quenched and Tempered.
- Forged jaw ends are fitted with bolts and nuts on sizes 6 mm through 64 mm, and pins and cotters on sizes 19 mm through 70 mm.
- Modified UNJ thread for improved fatigue properties.
- Fatigue Rated.

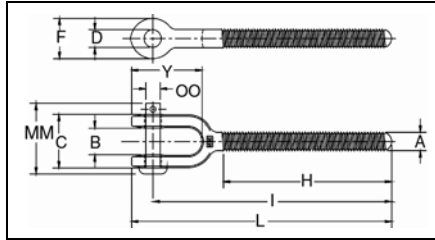

HG-4037 Jaw End Fittings

Shank Diameter & Take Up (in.)	Shank Diameter & Take Up (mm)	RH Jaw Stock No.	LH Jaw Stock No.	Working Load Limit (t)	Weight Each (kg)	Dimensions (mm)										
						A	B	C	D	F	H	I Nom. Min.	L Nom. Min.	Y	MM	OO Bolt-Pin
1/4 x 4	6.35 x 102	1072298	1072911	.23	.05	6.35	11.4	22.9	7.60	16.0	65.0	91.0	100	28.4	35.8	6.35
5/16 x 4-1/2	7.94 x 114	1072314	1072939	.36	.09	7.85	12.7	25.4	7.60	17.5	74.0	109	119	35.3	35.8	6.35
3/8 x 6	9.53 x 152	1072332	1072957	.54	.13	9.65	13.7	27.4	9.15	20.6	96.5	164	178	37.8	40.1	7.85
1/2 x 6	12.7 x 152	1072350	1072975	1.00	.26	12.7	16.5	36.3	10.7	25.4	103	202	216	46.0	47.2	9.65
1/2 x 9	12.7 x 229	1072378	1072993	1.00	.29	12.7	16.5	36.3	10.7	25.4	141	240	254	46.0	47.2	9.65
1/2 x 12	12.7 x 305	1072396	1073019	1.00	.32	12.7	16.5	36.3	10.7	25.4	179	185	205	46.0	47.2	9.65
5/8 x 6	15.9 x 305	1072412	1073037	1.59	.49	16.0	20.1	42.7	14.0	33.3	109	223	243	59.5	62.0	12.7
5/8 x 9	15.9 x 229	1072430	1073055	1.59	.54	16.0	20.1	42.7	14.0	33.3	147	261	281	59.5	62.0	12.7
5/8 x 12	15.9 x 305	1072458	1073073	1.59	.60	16.0	20.1	42.7	14.0	33.3	185	205	230	59.5	62.0	12.7
3/4 x 6	19.1 x 152	1072476	1073091	2.36	.78	19.1	23.9	50.0	17.5	41.1	116	243	268	71.0	65.0	15.7
3/4 x 9	19.1 x 229	1072494	1073117	2.36	.82	19.1	23.9	50.0	17.5	41.1	154	281	306	71.0	65.0	15.7
3/4 x 12	19.1 x 305	1072519	1073135	2.36	.95	19.1	23.9	50.0	17.5	41.1	192	357	382	71.0	65.0	15.7
3/4 x 18	19.1 x 457	1072537	1073153	2.36	1.12	19.1	23.9	50.0	17.5	41.1	268	303	331	71.0	65.0	15.7
7/8 x 12	22.2 x 305	1072555	1073171	3.27	1.50	22.4	28.7	61.5	20.6	47.8	198	379	407	82.0	78.5	19.1
7/8 x 18	22.2 x 457	1072573	1073199	3.27	1.73	22.4	28.7	61.5	20.6	47.8	274	249	280	82.0	78.5	19.1
1 x 6	25.4 x 152	1072591	1073215	4.54	1.77	25.4	34.0	67.0	23.9	54.0	128	223	255	94.5	87.5	22.4
1 x 12	25.4 x 305	1072617	1073233	4.54	2.07	25.4	34.0	67.0	23.9	54.0	204	299	331	94.5	87.5	22.4
1 x 18	25.4 x 457	1072635	1073251	4.54	2.34	25.4	34.0	67.0	23.9	54.0	281	376	407	94.5	87.5	22.4
1 x 24	25.4 x 610	1072653	1073279	4.54	2.61	25.4	34.0	67.0	23.9	54.0	357	452	483	94.5	87.5	22.4
1-1/4 x 12	31.8 x 305	1072671	1073297	6.89	3.37	31.8	44.5	91.5	31.0	66.5	210	336	375	124	115	28.4
1-1/4 x 18	31.8 x 457	1072699	1073313	6.89	3.80	31.8	44.5	91.5	31.0	66.5	287	412	451	124	115	28.4
1-1/4 x 24	31.8 x 610	1072715	1073331	6.89	4.29	31.8	44.5	91.5	31.0	66.5	363	488	528	124	115	28.4
1-1/2 x 12	38.1 x 305	1072733	1073359	9.71	5.62	38.1	52.3	101	37.3	79.0	221	354	400	134	130	35.1
1-1/2 x 18	38.1 x 457	1072751	1073377	9.71	6.30	38.1	52.3	101	37.3	79.0	298	431	476	134	130	35.1
1-1/2 x 24	38.1 x 610	1072779	1073395	9.71	8.95	38.1	52.3	101	37.3	79.0	374	507	552	134	130	35.1
1-3/4 x 18	44.5 x 457	1072813	1073439	12.7	8.95	44.5	66.0	118	43.7	89.0	309	470	523	159	152	41.1
1-3/4 x 24	44.5 x 610	1072831	1073457	12.7	8.95	44.5	66.0	118	43.7	89.0	385	546	599	159	152	41.1
2 x 24	51.0 x 610	1072859	1073475	16.8	16.5	51.0	66.5	142	53.0	106	396	604	670	184	174	51.0
2-1/2 x 24	63.5 x 610	1072877	1073493	27.2	28.3	63.5	76.5	148	60.5	143	437	650	739	229	190	57.0
2-3/4 x 24	70.0 x 610	1072895	1073518	34.0	42.9	70.0	92.2	167	73.0	155	441	679	781	242	214	70.0

Rigging Accessories

Turnbuckles - Body Only



Fatigue Rated

HG-2510 BODY

- Hot Dip galvanized.
- Heat treat by normalizing.
- UNC threads
- Fatigue Rated.
- Meets the performance requirements of Federal Specifications FF-T-791b, Type 1, Form 1 - Class 2, except for those provisions required by the contractor.

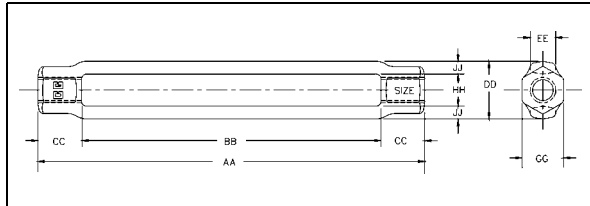

Shank Diameter & Take Up (in.)	Shank Diameter & Take Up (mm)	HG-2510 Stock No.	Working Load Limit (t)	Weight Each (kg)	Dimensions (mm)							
					AA	BB	CC	DD	EE	GG	HH	JJ
1/4 x 4	6.35 x 102	1033893	.23	.07	121	102	9.65	18.3	8.65	12.7	9.65	4.30
5/16 x 4-1/2	7.94 x 114	1033919	.36	.09	138	114	11.9	20.6	9.65	14.2	11.2	4.85
3/8 x 6	9.53 x 152	1033937	.54	.13	181	152	14.2	22.4	9.65	15.7	12.7	4.85
1/2 x 6	12.7 x 152	1033955	1.00	.27	191	152	19.1	28.4	12.7	20.6	15.7	6.35
1/2 x 9	12.7 x 229	1033973	1.00	.31	267	229	19.1	28.4	12.7	20.6	15.7	6.35
1/2 x 12	12.7 x 305	1033991	1.00	.45	343	305	19.1	28.4	12.7	20.6	15.7	6.35
5/8 x 6	15.9 x 305	1034017	1.59	.41	200	152	23.9	35.1	15.7	25.4	19.1	7.85
5/8 x 9	15.9 x 229	1034035	1.59	.54	276	229	23.9	35.1	15.7	25.4	19.1	7.85
5/8 x 12	15.9 x 305	1034053	1.59	.65	353	305	23.9	35.1	15.7	25.4	19.1	7.85
3/4 x 6	19.1 x 152	1034071	2.36	.59	210	152	28.4	42.9	19.1	28.4	23.9	9.65
3/4 x 9	19.1 x 229	1034099	2.36	.79	286	229	28.4	42.9	19.1	28.4	23.9	9.65
3/4 x 12	19.1 x 305	1034115	2.36	.94	362	305	28.4	42.9	19.1	28.4	23.9	9.65
3/4 x 18	19.1 x 457	1034133	2.36	1.13	514	457	28.4	42.9	19.1	28.4	23.9	9.65
7/8 x 12	22.2 x 305	1034179	3.27	1.22	371	305	33.3	49.3	22.4	33.3	26.9	11.2
7/8 x 18	22.2 x 457	1034197	3.27	1.72	524	457	33.3	49.3	22.4	33.3	26.9	11.2
1 x 6	25.4 x 152	1034213	4.54	1.12	229	152	38.1	57.0	25.4	38.1	31.8	12.7
1 x 12	25.4 x 305	1034231	4.54	1.78	381	305	38.1	57.0	25.4	38.1	31.8	12.7
1 x 18	25.4 x 457	1034259	4.54	2.39	533	457	38.1	57.0	25.4	38.1	31.8	12.7
1 x 24	25.4 x 610	1034277	4.54	3.35	686	610	38.1	57.0	25.4	38.1	31.8	12.7
1-1/4 x 12	31.8 x 305	1034339	6.89	2.38	384	305	39.6	66.5	31.8	47.8	38.1	14.2
1-1/4 x 18	31.8 x 457	1034357	6.89	3.52	536	457	39.6	66.5	31.8	47.8	38.1	14.2
1-1/4 x 24	31.8 x 610	1034375	6.89	4.61	689	610	39.6	66.5	31.8	47.8	38.1	14.2
1-1/2 x 12	38.1 x 305	1034437	9.71	3.97	400	305	47.8	76.0	38.1	57.0	44.5	15.7
1-1/2 x 18	38.1 x 457	1034455	9.71	4.99	552	457	47.8	76.0	38.1	57.0	44.5	15.7
1-1/2 x 24	38.1 x 610	1034473	9.71	6.21	705	610	47.8	76.0	38.1	57.0	44.5	15.7
1-3/4 x 18	44.5 x 457	1034552	12.7	7.43	568	457	55.5	92.0	44.5	66.5	54.0	19.1
1-3/4 x 24	44.5 x 610	1034570	12.7	9.64	721	610	55.5	92.0	44.5	66.5	54.0	19.1
2 x 24	51.0 x 610	1034632	16.8	12.5	737	610	63.5	105	51.0	76.0	60.5	22.4
2-1/2 x 24	63.5 x 610	1034678	27.2	24.5	789	610	89.5	143	70.0	98.5	79.0	31.8
2-3/4 x 24	70.0 x 610	1034696	34.0	24.5	789	610	89.5	143	70.0	98.5	79.0	31.8

Stub End Turnbuckles

HS-251



- Complete assembly is self - colored.
- End fittings are Quenched and Tempered, bodies heat treated by normalizing.
- Reference American Welding Society Specifications for proper welding procedures.
- Meets the performance requirements of Federal Specifications FF-T-791b, Type 1, Form 1 - CLASS 3, and ASTM F-1145, except for those provisions required of the contractor.

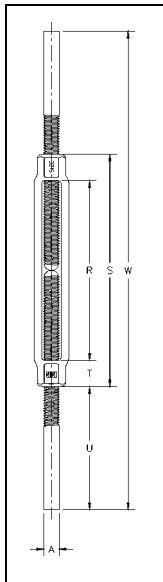

LOCK NUTS

HS-251 Stub End Turnbuckles

Shank Diameter & Take up (in.)	Shank Diameter & Take up (mm)	HS-251 Stock No.	Working Load Limit (t)	Weight Each (kg)	Dimensions (mm)					
					A	R	S	T	U	W
3/8 x 6	9.53 x 152	1033143	.54	.34	9.65	152	181	14.2	113	406
1/2 x 6	12.7 x 152	1033161	1.00	.57	12.7	152	190	19.1	108	406
5/8 x 6	15.9 x 305	1033223	1.59	.96	16.0	152	200	23.8	103	406
3/4 x 6	19.1 x 152	1033287	2.36	1.48	19.1	152	209	28.7	111	431
7/8 x 6	22.2 x 152	1033367	3.27	2.17	22.4	152	219	33.2	119	457
1 x 6	25.4 x 152	1033429	4.54	2.88	25.4	152	228	38.1	127	482
1 x 12	25.4 x 305	1033447	4.54	3.99	25.4	304	381	38.1	127	635
1-1/8 x 6	28.6 x 152	1033508	5.62	4.03	28.7	152	231	39.6	125	482
1-1/4 x 6	31.8 x 152	1033526	6.89	4.62	31.8	152	231	39.6	138	508
1-1/4 x 12	31.8 x 305	1033544	6.89	6.17	31.8	304	384	39.6	138	660
1-1/2 x 12	38.1 x 305	1033642	9.71	9.27	38.1	304	400	47.7	137	673

Rigging Accessories

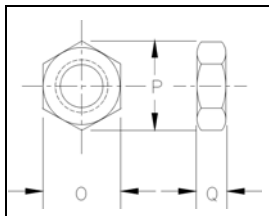

HG-4060 / HG-4061 Lock Nuts

Thread Diameter (in.)	Right Hand HG-4060 Stock No.	Left Hand HG-4061 Stock No.	Weight Per 100 (kg)	Dimensions (mm)		
				O	P	Q
1/4	1075115	1075491	.36	11.2	12.7	4.05
5/16	1075133	1075516	.59	12.7	14.2	4.85
3/8	1075151	1075534	.91	14.2	16.3	5.60
1/2	1075197	1075570	1.81	19.1	21.8	7.85
5/8	1075213	1075598	3.18	23.9	26.9	9.65
3/4	1075231	1075614	4.99	28.7	32.0	10.7
7/8	1075259	1075632	7.39	33.3	38.1	12.2
1	1075277	1075650	10.8	38.1	42.9	14.0
1-1/4	1075311	1075696	28.3	47.8	54.0	18.3
1-1/2	1075357	1075730	32.7	57.0	64.5	21.3
1-3/4	1075393	1075776	51	70.0	81.0	25.4
2	1075419	1075794	68	79.0	91.5	28.4
2-1/2	1075455	1075838	150	98.5	114	38.1
2-3/4	1075473	1075856	193	108	125	41.1

FORGED EYE BOLT

WARNINGS AND APPLICATION INSTRUCTIONS

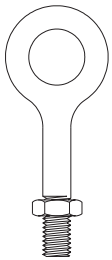

Regular Nut Eye Bolt
G-291

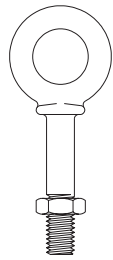

Shoulder Nut Eye Bolt
G-277

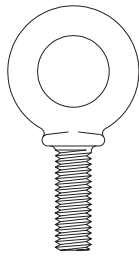

Machinery Eye Bolt
S-279

Important Safety Information - Read & Follow

Inspection/Maintenance Safety:

- Always inspect eye bolt before use.
- Never use eye bolt that shows signs of wear or damage.
- Never use eye bolt if eye or shank is bent or elongated.
- Always be sure threads on shank and receiving holes are clean.
- Never machine, grind, or cut eye bolt.

Assembly Safety:

- Never exceed load limits specified in Table 1.
- Never use regular nut eye bolts for angular lifts.
- Always use shoulder nut eye bolts (or machinery eye bolts) for angular lifts.
- For angular lifts, adjust working load as follows:

Direction of Pull	Adjusted Working Load
45 degrees	30% of rated working load
90 degrees	25% of rated working load

- Never undercut eye bolt to seat shoulder against the load.
- Always countersink receiving hole or use washers to seat shoulder.
- Always screw eye bolt down completely for proper seating.
- Always tighten nuts securely against the load.

Size (mm)	Working Load Limit (kg)
6.35	295
7.94	544
9.53	703
12.7	1179
15.9	2351
19.1	3266
22.2	4808
25.4	6033
31.8	9525
38.1	10886

WARNING

- Loads may slip or fall if proper eye bolt assembly and lifting procedures are not used.
- A falling load can seriously injure or kill.
- Read and understand both sides of these instructions, and follow all eye bolt safety information presented here.
- Read, understand, and follow information in diagrams and charts below before using eye bolt assemblies.

Shoulder Nut Eye Bolt — Installation for Angular Loading

IN - LINE

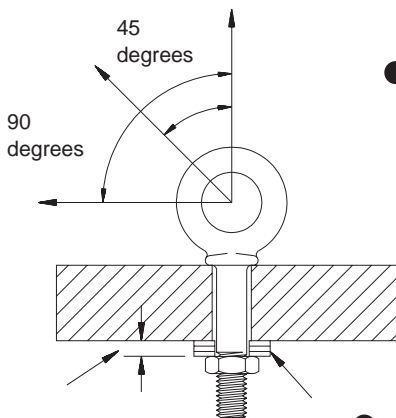

- The threaded shank must protrude through the load sufficiently to allow full engagement of the nut.
- If the eye bolt protrudes so far through the load that the nut cannot be tightened securely against the load, use properly sized washers to take up the excess space BETWEEN THE NUT AND THE LOAD.

- Thickness of spacers must exceed this distance between the bottom of the load and the last thread of the eye bolt.
- Place washers or spacers between nut and load so that when the nut is tightened securely, the shoulder is secured flush against the load surface.

IMPORTANT - Read and understand these instructions before using eye bolts.

Regular Nut & Shoulder Nut Eye Bolt - Installation for In-line Loading

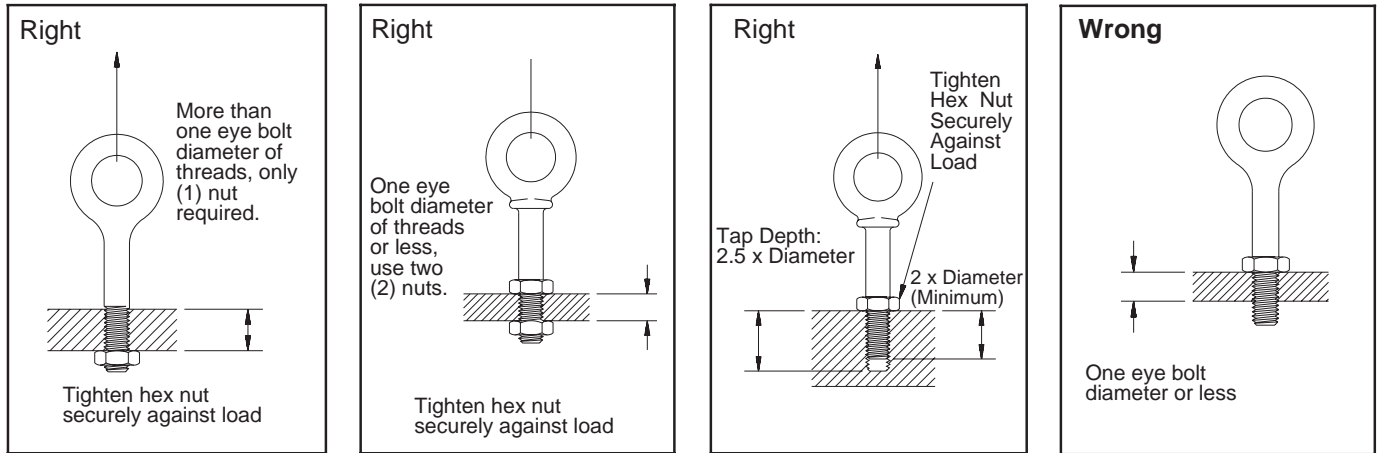

Operating Safety

- Always stand clear of load.
- Always lift load with steady, even pull – do not jerk.
- Always apply load to eye bolt in the plane of the eye – not at an angle.
- Never exceed the capacity of the eye bolt—see Table I.
- When using lifting slings of two or more legs, make sure the loads in the legs are calculated using the angle from the vertical to the leg and properly size the shoulder nut or machinery eye bolt for the angular load.

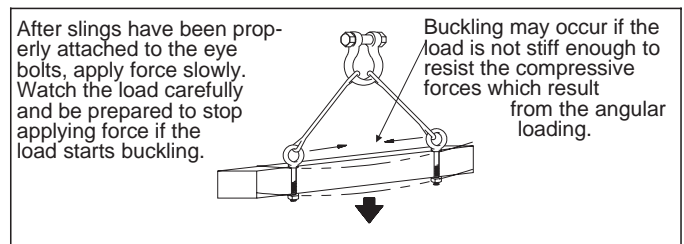
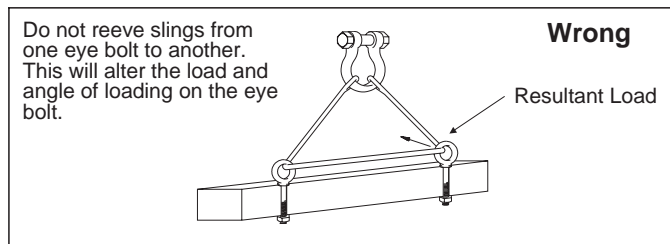

Machinery Eye Bolt - Installation for In – line & Angular Loading

These eye bolts are primarily intended to be installed into tapped holes.

1. After the loads on the eye bolts have been calculated, select the proper size eye bolt for the job. For angular lifts, adjust working load as follows:

Direction of Pull	Adjusted Working Load
45 degrees	30% of rated working load
90 degrees	25% of rated working load

2. Drill and tap the load to the correct sizes to a minimum depth of one-half the eye bolt size beyond the shank length of the machinery eye bolt.
3. Thread the eye bolt into the load until the shoulder is flush and securely tightened against the load.
4. If the plane of the machinery eye bolt is not aligned with the sling line, estimate the amount of unthreading rotation necessary to align the plane of the eye properly. Remove the machinery eye bolt from the load and add shims (washers) of proper thickness to adjust the angle of the plane of the eye to match the sling line. Use Table II to estimate the required shim thickness for the amount of unthreading rotation required.

Eye Bolt Size (mm)	Shim Thickness Required to Change Rotation 90° (mm)
6.35	0.30
7.94	0.35
9.53	0.40
12.7	0.50
15.9	0.60
19.1	0.65
22.2	0.70
25.4	0.80
31.8	0.90
38.1	1.05

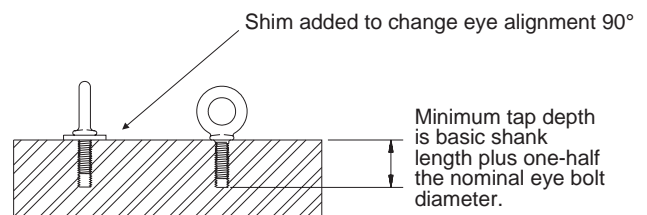

CROSBY® SWIVEL HOIST RINGS

WARNINGS AND APPLICATION INSTRUCTIONS

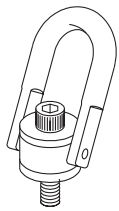

HR-125
(Red Washer)
HR-125 M
(Silver Washer)



HR-1000
(Red Washer)
HR-1000M
(Silver Washer)

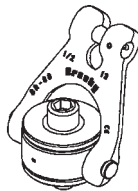

HR-125C

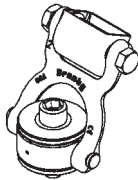

HR-125W

Hoist Ring Application Assembly Safety

- Use swivel hoist ring only with a ferrous metal (steel, iron) or soft metal (i.e., aluminum) loads (work piece). Do not leave threaded end of hoist ring in aluminum loads for long time periods due to corrosion.
- After determining the loads on each hoist ring, select the proper size hoist ring using the Working Load Limit ratings in Table 1,2,& 4 for UNC threads and Table 3 for Metric threads.
- Drill and tap the work piece to the correct size to a minimum depth of one-half the threaded shank diameter plus the threaded shank length. See rated load limit and bolt torque requirements imprinted on top of the swivel trunnion (See Table 1 and/or Table 3).
- Install hoist ring to recommended torque with a torque wrench making sure the bushing flange meets the load (work piece) surface.
- Never use spacers between bushing flange and mounting surface.
- Always select proper load rated lifting device for use with Swivel Hoist Ring.
- Attach lifting device ensuring free fit to hoist ring bail (lifting ring) (Fig. 1)
- Apply partial load and check proper rotation and alignment. There should be no interference between load (work piece) and hoist ring bail (Fig. 2)
- **Special Note:** When a Hoist Ring is installed with a retention nut, the nut must have a full thread engagement and must meet one of the following standards to develop the Working Load Limit (WLL).
 - 1.ASTM A-563 (A) Grade D Hex Thick
(B) Grade DH Standard Hex
 - 2.SAE Grade 8 — Standard Hex

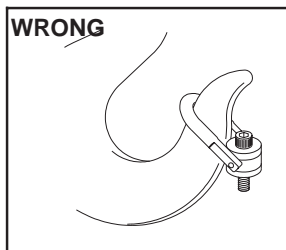

Figure 1

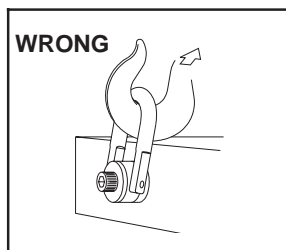

Figure 2

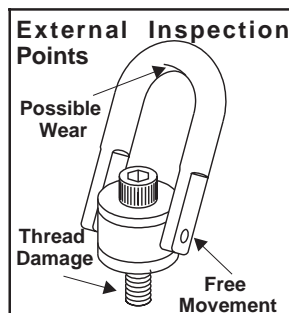

Figure 3

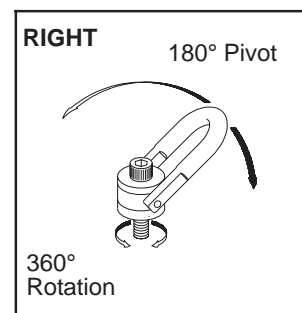

Figure 4



WARNING

- Loads may slip or fall if proper Hoist Ring assembly and lifting procedures are not used. Read and Understand these warnings and application instructions.
- A falling load may cause serious injury or death.
- Install hoist ring bolt to torque requirements listed in tables 1,2,3, & 4. For the HR-125,HR-1000, HR125C, HR-125M, HR-1000M and HR125W respectively.
- Web sling HR-125W connecting bolt must be securely tightened in place. The jam nut must then be securely tightened onto the connecting bolt, see Table 4, last column.
- Chain sling HR-125C connecting pin must be in place properly secured with the locking pin into the clevis ears.
- Do not use with damaged slings or chain. For inspection criteria see ASME B30.9
- Use only genuine Crosby parts as replacements.

Hoist Ring Inspection / Maintenance

- Always inspect hoist ring before use.
- Regularly inspect hoist ring parts (Fig.3).
- Never use hoist ring that shows signs of corrosion, wear or damage.
- Never use hoist ring if bail is bent or elongated.
- Always be sure threads on shank and receiving hole are clean, not damaged, and fit properly.
- Always check with torque wrench before using an already installed hoist ring.
- Always make sure there are no spacers (washers) used between bushing flange and the mounting surface. Remove any spacers (washers) and retorque before use.
- Always ensure free movement of bail. The bail should pivot 180 degrees and swivel 360 degrees (Fig. 4).
- Always be sure total work piece surface is in contact with hoist ring bushing mating surface. Drilled and tapped hole must be 90 degrees to load (work piece) surface.

Operating Safety

- Never exceed the capacity of the swivel hoist ring, see Table 1,2, and 4 for UNC threads and Table 3 for Metric threads.
- When using lifting slings of two or more legs, make sure the forces in the legs are calculated using the angle from the vertical to the leg and select the proper size swivel hoist ring to allow for the angular forces.

Working Load Limit* 5:1 (lbs.)	Hoist Ring Bolt Torque in Ft. lbs. †	HR-125		HR-1000	
		HR-125 Bolt Size ‡ (in.)	Effective Thread Projection Length (in.)	HR-1000 Bolt Size ‡ (in.)	Effective Thread Projection Length (in.)
800 ††	7	5/16 - 18 x 1.50	.59	5/16 - 18 x 1.50	.52
1000 ††	12	3/8 - 16 x 1.50	.59	3/8 - 16 x 1.50	.52
2500	28	1/2 - 13 x 2.00	.71	1/2 - 13 x 2.25	.69
2500 ††	28	1/2 - 13 x 2.50	1.21	1/2 - 13 x 2.75	1.19
4000	60	5/8 - 11 x 2.00	.71	5/8 - 11 x 2.25	.69
4000 ††	60	5/8 - 11 x 2.75	1.46	5/8 - 11 x 3.00	1.44
5000	100	3/4 - 10 x 2.25	.96	3/4 - 10 x 2.50	.94
5000 ††	100	3/4 - 10 x 2.75	1.46	3/4 - 10 x 3.00	1.44
7000 **	100	3/4 - 10 x 2.75	.90	3/4 - 10 x 3.00	.85
7000 †††	100	3/4 - 10 x 3.50	1.65	3/4 - 10 x 4.00	1.85
8000	160	7/8 - 9 x 2.75	.90	7/8 - 9 x 3.00	.85
8000 ††	160	7/8 - 9 x 3.50	1.65	7/8 - 9 x 4.00	1.85
10000	230	1 - 8 x 3.00	1.15	1 - 8 x 3.50	1.35
10000 ††	230	1 - 8 x 4.00	2.15	1 - 8 x 4.50	2.35
15000	470	1 1/4 - 7 x 4.50	2.22	1 1/4 - 7 x 5.00	2.09
24000	800	1 1/2 - 6 x 6.50	2.98	1 1/2 - 6 x 5.50	2.59
30000	1100	2 - 4 1/2 x 6.50	2.98	—	—
50000	2100	2 1/2 - 4 x 8.00	4.00	—	—
75000	4300	3 - 4 x 10.50	5.20	—	—
100000	6600	3 1/2 - 4 x 13.00	7.00	—	—

** Ultimate Load is 4.5 times Working Load Limit for 7000# Hoist Ring when Tested in 90° orientation. All sizes are individually proof tested to 2-1/2 times the Working Load Limit.

†, ††, ††† (See footnote at bottom of page).

HR-125C Swivel Hoist Ring to Grade 8 Chain				
Working Load Limit 4:1 (lbs.)**	Hoist Ring Bolt Torque in Ft. lbs. †	Bolt Size (in.) ‡	Effective Thread Projection Length (in.)	Spectrum 8 Chain Size (in. - mm)
4500	60	5/8 - 11 x 2.00	.71	1/4 - 7
4500††	60	5/8 - 11 x 2.75	1.46	1/4 - 7
7100	100	3/4 - 10 x 2.75	.90	3/8 - 10
7100††	100	3/4 - 10 x 3.50	1.65	3/8 - 10
12000	230	1 - 8 x 3.00	1.15	1/2 - 13
12000††	230	1 - 8 x 4.00	2.15	1/2 - 13
18100	470	1-1/4 - 7 x 4.00	2.22	5/8 - 16

See footnote at bottom of page.

Working Load Limit (Kg)***		Hoist Ring Bolt Torque in Nm †	HR-125M		HR-1000M	
Design Factor 5:1	Design Factor 4:1		Bolt Size †† (mm)	HR-125M Effective Thread Projection Length (mm)	Bolt Size †† (mm)	HR-1000M Effective Thread Projection Length (mm)
400	500	10	M 8 x 1.25 x 40	16.9	M 8 x 1.25 x 40	16.0
450	550	16	M10 x 1.50 x 40	16.9	M10 x 1.50 x 40	16.0
1050	1300	38	M12 x 1.75 x 50	17.2	M12 x 1.75 x 55	15.5
1900	2400	81	M16 x 2.00 x 60	27.2	M16 x 2.00 x 65	26.1
2150	2700	136	M 20 x 2.50 x 65	31.2	M 20 x 2.50 x 70	31.1
3000	3750	136	M 20 x 2.50 x 75	28.1	M 20 x 2.50 x 80	25.4
4200	5250	312	M 24 x 3.00 x 80	33.1	M 24 x 3.00 x 90	36.0
7000	8750	637	M 30 x 3.50 x 100	45.1	M 30 x 3.50 x 130	66.8
11000	13750	1005	M 36 x 4.00 x 150	60.6	M 36 x 4.00 x 130	56.2
12500	15600	1005	M 42 x 4.50 x 160	70.6	—	—
13500	16900	1350	M 48 x 5.00 x 160	70.6	—	—

Designed to be used with ferrous work piece only.

HR-125W Swivel Hoist Ring to Webbing									
HR-125W Web Sling				HR-125W Working Load Limit 5:1 (tons) *	Hoist Ring Bolt Torque in Ft. lbs. †	Bolt Size (in.) ‡	Effective Thread Projection Length (in.)	Torque in Ft.-Lbs. Spool bolt and nut †††	
Round Sling Size (No.)	Web Width (in.)	Eye Width (in.)	Ply.						
1 & 2	2	2	2	3-1/4	100	3/4 - 10 x 2.75	.90	90	
1 & 2	2	2	2	3-1/4††	100	3/4 - 10 x 3.50	1.65	90	
3	3	1.5	2	4-1/2	230	1 - 8 x 3.00	1.15	110	
3	3	1.5	2	4-1/2††	230	1 - 8 x 4.00	2.15	110	
4	4	2	2	6-1/4	470	1-1/4 - 7 x 4.50	2.22	130	

* Ultimate load is 5 times the Working Load Limit. Individually proof tested to 2-1/2 times the Working Load Limit.

** Ultimate load is 4 times the Working Load Limit. Individually tested to 2-1/2 times the Working Load Limit.

*** Individually proof tested to 2-1/2 times the Working Load Limit based on 4:1 design factor.

† Tightening torque values shown are based upon threads being clean, dry and free of lubrication.

†† Long bolts are designed to be used with soft metal (i.e., aluminum) work piece. While the long bolts may also be used with ferrous metal (i.e., steel & iron) work pies, short bolts are designed for ferrous work pieces only.

‡ Bolt specification is a Grade 8 Alloy socket head cap screw to ASTM A574. All threads are UNC.

‡‡ Bolt specification is a Grade 12.9 Alloy socket head cap to DIN 912. All threads are metric (ASME/ANSI B18.3.1m)

‡‡‡ Tighten bolt to specified torque, then tighten nut to specified torque.

All Swivel Hoist Rings are individually proof tested to 2-1/2 times the Working Load Limit.

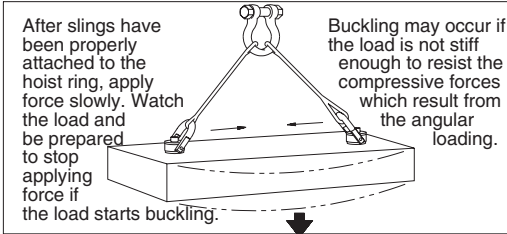
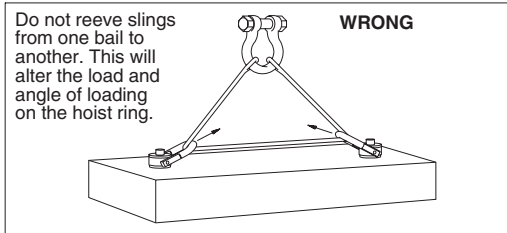

WARNING

- A falling load may cause serious injury or death.
- Chain sling HR-125C connecting pin must be properly secured with the locking pin into the clevis ears.
- Do not use with damaged web slings or chain. For inspection criteria see ASME B30.9
- Before use, tighten bolt first, then tighten nut. (HR-125W)
- Read, understand and follow all instructions and chart information before using web connector.

WARNING AND APPLICATION INSTRUCTIONS



HR-1200

Hoist Ring Application / Assembly Instruction

- The Crosby side pull swivel hoist ring is designed to accept standard Crosby fittings to facilitate wider slings and quick attachment. In order to use the larger fittings, the load rating on the (shackle) fitting may be greater than the hoist ring frame. **Never exceed the Working Load Limit of the hoist ring frame.**
- Use swivel hoist ring only with a ferrous metal (steel, iron) or non-ferrous (i.e., aluminum) loads (work piece). Do not leave threaded end of hoist ring in aluminum loads for long time periods due to corrosion.
- After determining the loads on each hoist ring, select the proper size hoist ring using the working Load Limit ratings in Table 1 for UNC threads and Table 2 for Metric threads.
- Drill and tap the work piece to the correct size to a minimum depth of one-half the threaded shank diameter plus the threaded shank length.
- Install hoist ring to recommended torque with a torque wrench making sure the bushing flange is fully supported by the load (work piece) surface. See rated load limit and bolt torque requirements imprinted on hoist ring body (See Table 1 or Table 2).
- Never use spacers between bushing flange and mounting surface.
- Always select proper lifting device for use with Swivel Hoist Ring (See Tables 1 & 2).
- Attach lifting device ensuring free fit to hoist shackle (See Figure 3).
- Apply partial load and check proper rotation and alignment of shackle. There should be no interference between load (work piece) and hoist shackle (See Figure 1 and Figure 3).
- The Hoist ring should rotate into normal operating position, with shackle aligned with load as shown in Figure 3. If shackle is oriented as shown in Figure 4, **DO NOT LIFT.**
- **Special Note:** when a Hoist Ring is installed with a retention nut, the nut must have full thread engagement and must meet one of the following standards to develop the Working Load Limit (WLL).
 1. ASTM A-563 (A) Grade D Hex Thick (B) Grade DH Standard Hex
 2. SAE Grade 8 — Standard Hex

Hoist Ring Inspection / Maintenance

- Always inspect hoist ring before use.
- Regularly inspect hoist ring parts (Figure 2).
- For hoist rings used in frequent load cycles or on pulsating loads, the bolt threads should be periodically inspected by magnetic particle or dye penetrant.
- Do not use part showing cracks, nicks or gouges.
- Repair minor nicks or gouges to hoist frame by lightly grinding until surfaces are smooth. Do not reduce original dimension more than 10%. Do not repair by welding.

WARNING

- Loads may slip or fall if proper Hoist Ring assembly and lifting procedures are not followed.
- A falling load may cause serious injury or death.
- Install hoist ring bolt to torque requirements listed in tables.
- The side pull hoist ring frame will be only one part of a lifting system with several components (i.e., shackles and slings). Never exceed the Working Load Limit of the hoist ring frame.
- Do not use damaged slings or chain. For inspection criteria, see ASME B30.9.
- Read and understand these instructions before using hoist ring.
- Use only genuine Crosby parts as replacements.

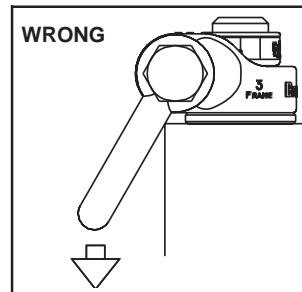

Figure 1

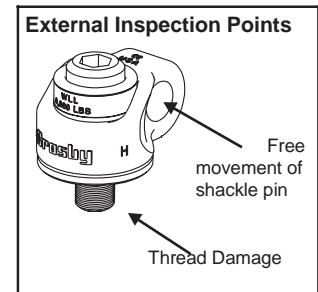

Figure 2

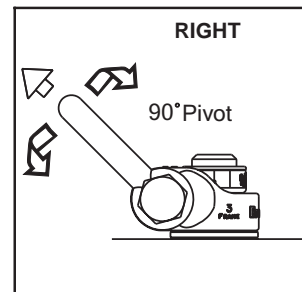

Figure 3

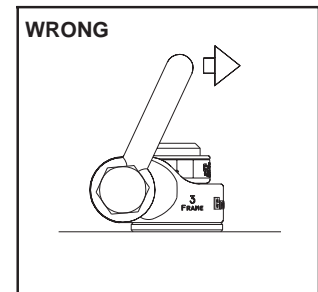
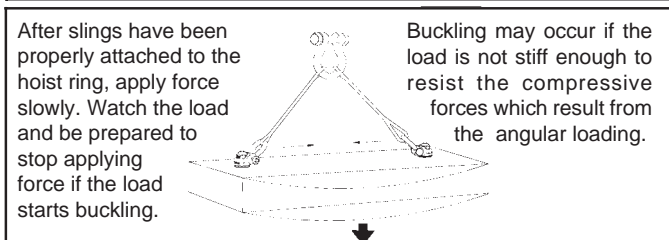
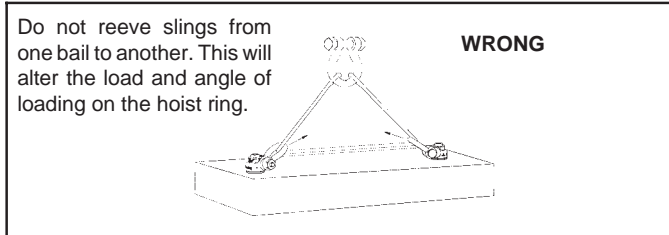

Figure 4

- Never use hoist ring that shows signs of corrosion, wear or damage.
- Never use hoist ring if components are bent or elongated.
- Always be sure threads on bolt and receiving tapped holes are clean, undamaged, and fit properly.
- Always check with torque wrench before using an already installed hoist ring.
- Always make sure there are no spacers (washers) used between bushing flange and the mounting surface. Remove any spacers (washers) and retorque before use.
- Always ensure free movement of shackle. The shackle should pivot 90° and the hoist ring should swivel 360° (See Figure 3).
- Always be sure total work piece surface is in contact with hoist ring bushing mating surface. Drilled and tapped hole must be 90° to load (work piece) surface.



OPERATING SAFETY

- Never exceed the capacity of the hoist ring, see Table 1 for UNC threads and Table 2 for Metric threads.
- When using lifting slings of two or more legs, make sure the forces in the legs are calculated using the angle from the vertical to the leg and select the proper size swivel hoist ring to allow for the angular forces.

HR1200 UNC Threads TABLE 1

Frame Size	Working Load Limit * (lbs.)	Hoist Ring Bolt Torque in Ft. Lbs.†	Bolt Size‡ (in.)	Effective Thread Projection Length (in.)	Recommended Shackles	
					Red Pin® Shackles 209, 210, 213, 215, 2130, 2150 (t)	Red Pin® Web Shackles S-281 (tons)
1	650††	7	5/16 - 18 x 1.5	.59	1/2" - (2)	2" - (3-1/4)
	800††	12	3/8 - 16 x 1.5	.59	5/8" - (3-1/4)	
2	2000	28	1/2 - 13 x 2.0	.71	5/8" - (3-1/4) 3/4" - (4-3/4)	2" - (3-1/4) 1-1/2" - (4-1/2)
	2000††	28	1/2 - 13 x 2.5	1.21		
	3000	60	5/8 - 11 x 2.0	.71		
	3000††	60	5/8 - 11 x 2.75	1.46		
3	5000	100	3/4 - 10 x 2.75	1.46	7/8" - (6-1/2)	2" - (6-1/4)
	5000††	100	3/4 - 10 x 3.5	1.65		
	6500	160	7/8 - 9 x 2.75	.90		
	6500††	160	7/8 - 9 x 3.5	1.65		
	8000	230	1 - 8 x 3.0	1.15		
	8000††	230	1 - 8 x 4.0	2.15		
4	14000	470	1-1/4 - 7 x 4.5	2.22	1" - (8-1/2)	3" - (8-1/2)
					1-1/8" - (9-1/2)	
					1-1/4" - (12)	
5	17200 29000	800 1100	1-1/2 - 6 x 6.5 2 - 4-1/2 x 6.5	2.98 2.98	1-3/8" - (13-1/2)	—
					1-1/2" - (17)	
					1-3/4 - (25)	

HR1200M Metric Threads TABLE 2

Frame Size	Working Load Limit * (kg)	Hoist Ring Bolt Torque Nm †	Bolt Size (mm) ‡	Effective Thread Projection Length (mm)	Recommended Shackles	
					Red Pin® Shackle 209, 210, 213, 215, 2130, 2150 (t)	Red Pin® Web Shackles S-281 (tons)
1	300	10	M8 x 1.25 x 40	16.9	1/2" - (2)	2" - (3-1/4)
	400	16	M10 x 1.5 x 40	16.9	5/8" - (3-1/4)	
2	1000	38	M12 x 1.75 x 50	17.2	5/8" - (3-1/4)	2" - (3-1/4) 1-1/2" - (4-1/2)
	1400	81	M16 x 2.00 x 60	27.2	3/4" - (4-3/4)	
3	2250	136	M20 x 2.50 x 75	28.1	7/8" - (6-1/2)	2" - (6-1/4)
	3500	312	M24 x 3.00 x 80	33.1		
4	6250	637	M30 x 3.5 x 120	45.1	1" - (8-1/2)	3" - (8-1/2)
					1-1/8" - (9-1/2)	
					1-1/4" - (12)	
5	7750 10000 13000	1005 1005 1350	M36 x 4.0 x 150 M42 x 4.5 x 160 M48 x 5.0 x 160	60.6 70.6 70.6	1-3/8" - (13-1/2)	—
					1-1/2" - (17)	
					1-3/4 - (25)	

Designed to be used with Ferrous work piece only

* Ultimate load is 5 times the Working Load Limit. Individually proof tested to 2-1/2 times the Working Load Limit.

† Tightening torque values shown are based upon threads being clean, dry and free of lubrication.

†† Long bolts are designed to be used with soft metal (i.e., aluminum) work piece. While the long bolts may also be used with ferrous metal (i.e., steel & iron) work pieces, short bolts are designed for ferrous work pieces only.

‡ Bolt specification is a Grade 8 Alloy socket head cap screw to ASTM A574. All threads are UNC - 3A.

‡‡ Bolt specification is a Grade 12.9 Alloy socket head cap to DIN 912. All threads are metric (ASME/ANSI B18.3.1m)